

ELEVATION LEGEND

- 1 CONCRETE 'S' TILE ROOFING
- 2 CONCRETE FLAT TILE ROOFING
- 3 WOOD FASCIA BOARD
- 4 STUCCO FINISH (16/20 SAND)
- 5 STUCCO OVER FOAM TRIM
- 6 DECORATIVE STUCCO FINISH OVER FOAM CORBELS/SHAPED FOAM TRIM
- 7 STUCCO COLUMN
- 8 VINYL WINDOW SYSTEM
- 9 COMPOSITE ENTRY DOOR
- 10 METAL SECTIONAL GARAGE DOOR
- 11 DECORATIVE SHUTTERS
- 12 DECORATIVE GABLE END DETAIL
- 13 COACH LIGHTS
- 14 DECORATIVE OUTLOOKERS
- 15 GARAGE WINDOWS
- 16 ADDRESS PLAQUE
- 17 DECORATIVE CLAY PIPE
- 18 STUCCO OVER FOAM POTSHELF
- 19 BOARD AND BATTEN
- 20 WOOD COLUMN
- 21 WOOD POST
- 22 DECORATIVE TILE
- 23 BRICK VENEER
- 24 STONE VENEER
- 25 WROUGHT IRON POTSHELF
- 26 EXPOSED RAFTER TAILS



Elevation 'A' (Spanish)



Elevation 'B' (Craftsman)



Elevation 'C' (Italianate)

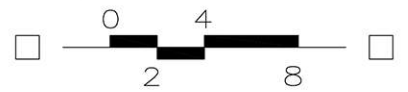

PLAN 1

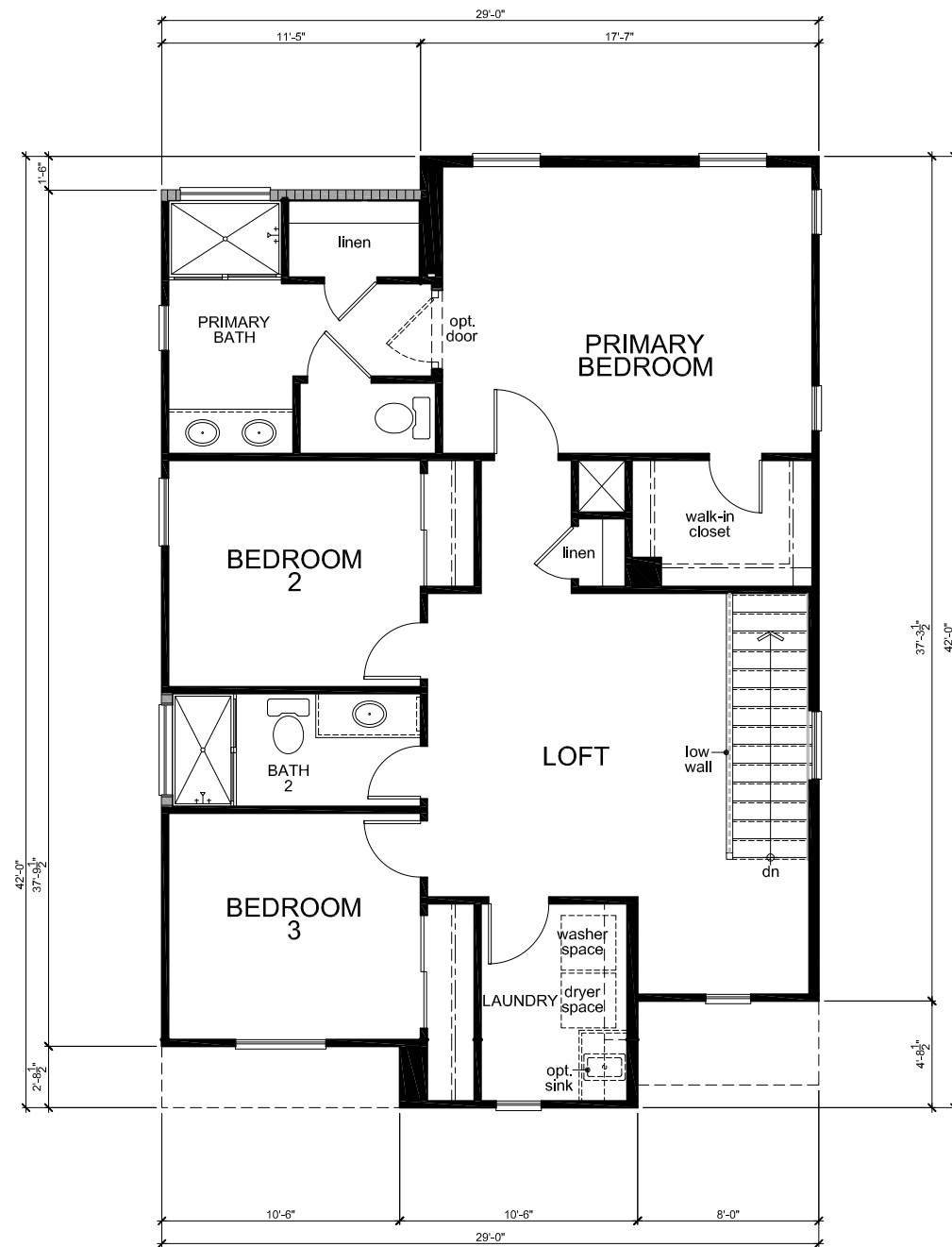

Second Floor Plan 'A'

SQUARE FOOTAGE			
PLAN 229.1791			
FIRST FLOOR AREA	124	SQ. FT.	
SECOND FLOOR AREA	1062	SQ. FT.	
TOTAL AREA	1186	SQ. FT.	
GARAGE AREA	494	SQ. FT.	
PORCH AREA(S)	30	SQ. FT.	
	ELEVATION 'A'	47	SQ. FT.
	ELEVATION 'B'	47	SQ. FT.
	ELEVATION 'C'	47	SQ. FT.

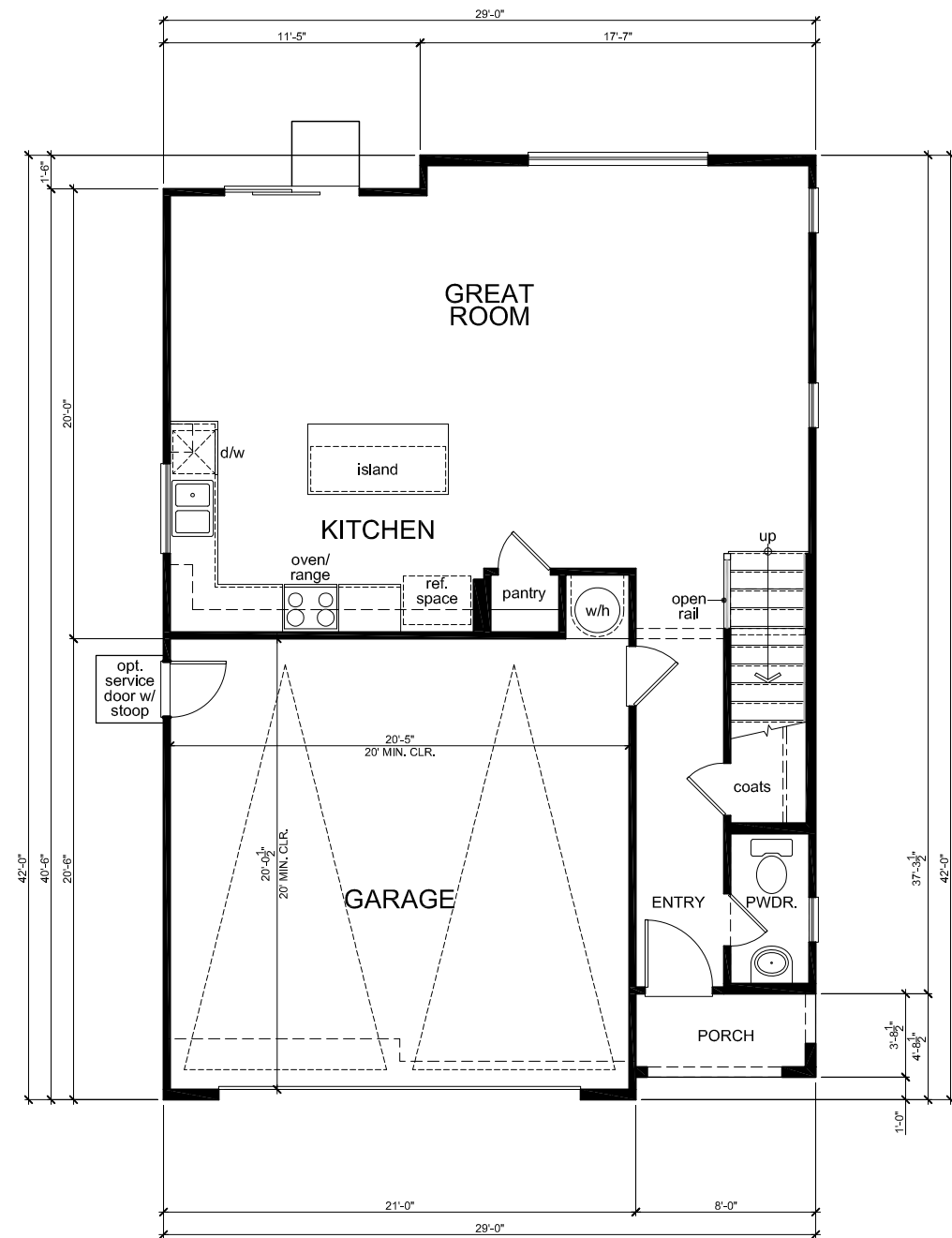

First Floor Plan 'A'

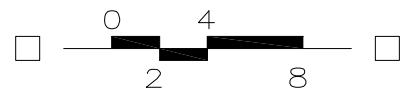

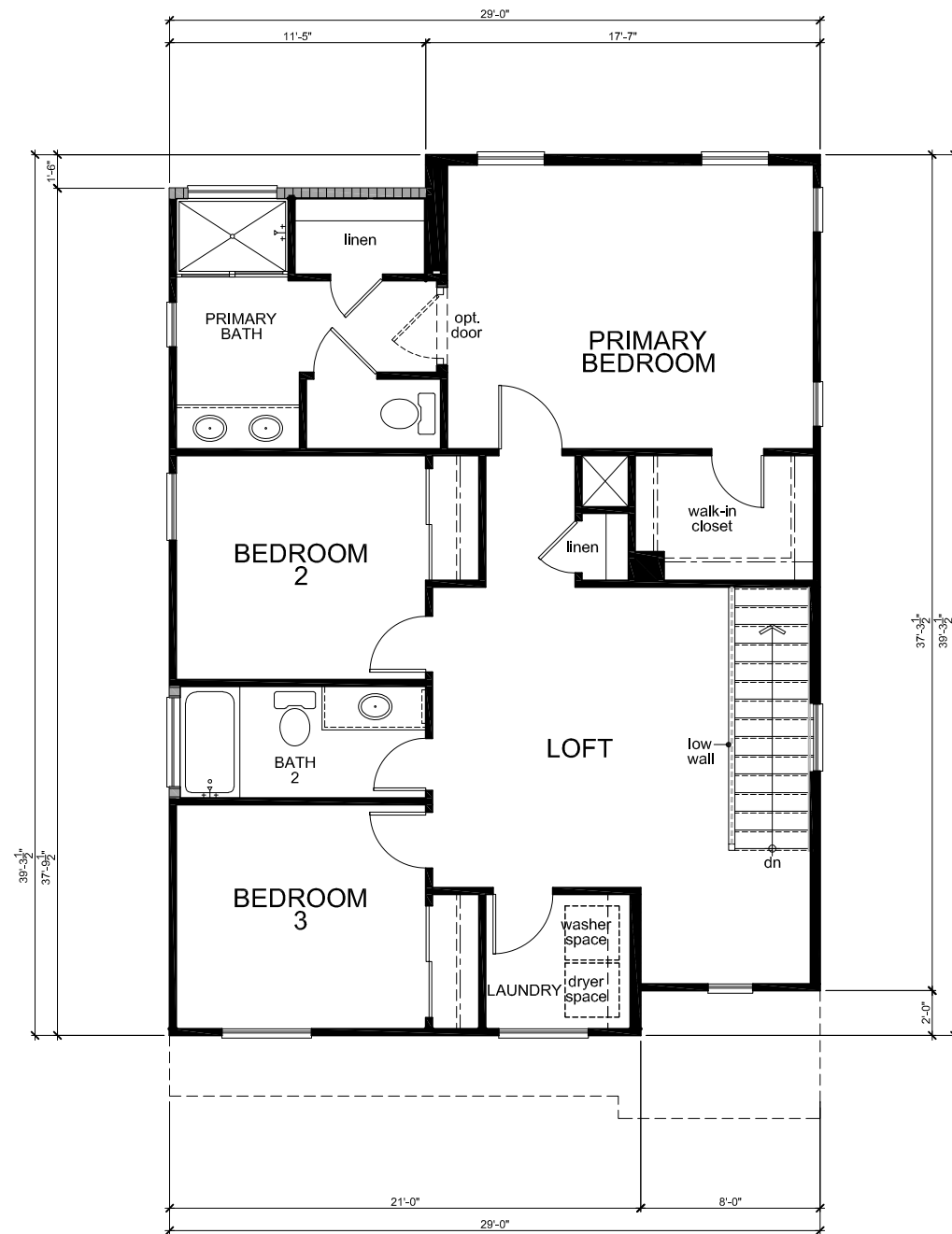

Second Floor Plan 'B'

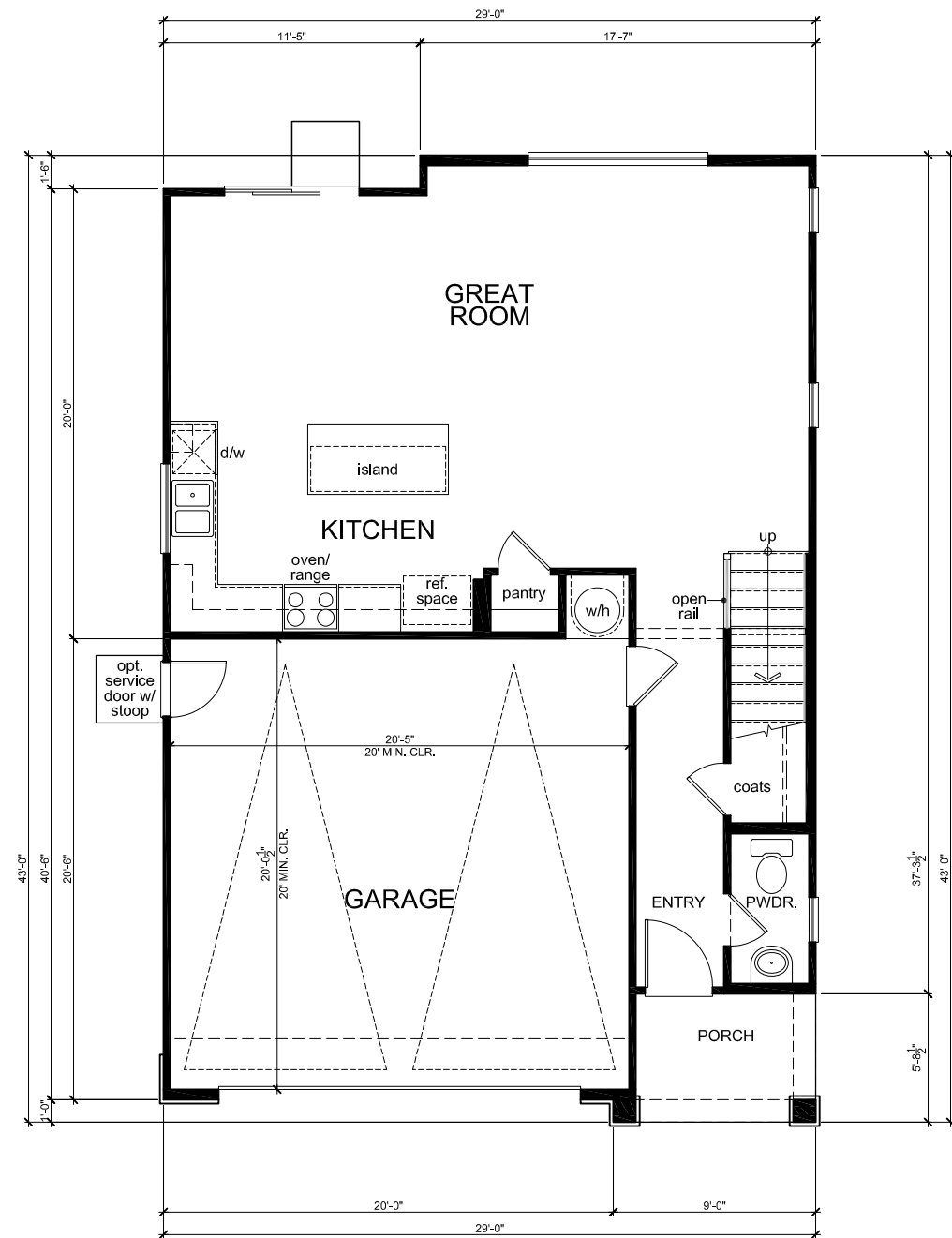

First Floor Plan 'B'

SQUARE FOOTAGE			
PLAN 229.1791			
FIRST FLOOR AREA	124	SQ. FT.	
SECOND FLOOR AREA	1062	SQ. FT.	
TOTAL AREA	1741	SQ. FT.	
GARAGE AREA	494	SQ. FT.	
PORCH AREA(S)	30	SQ. FT.	
	ELEVATION 'A'	47	SQ. FT.
	ELEVATION 'B'	47	SQ. FT.
	ELEVATION 'C'	47	SQ. FT.

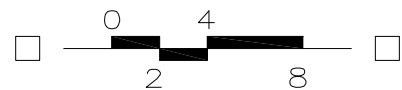

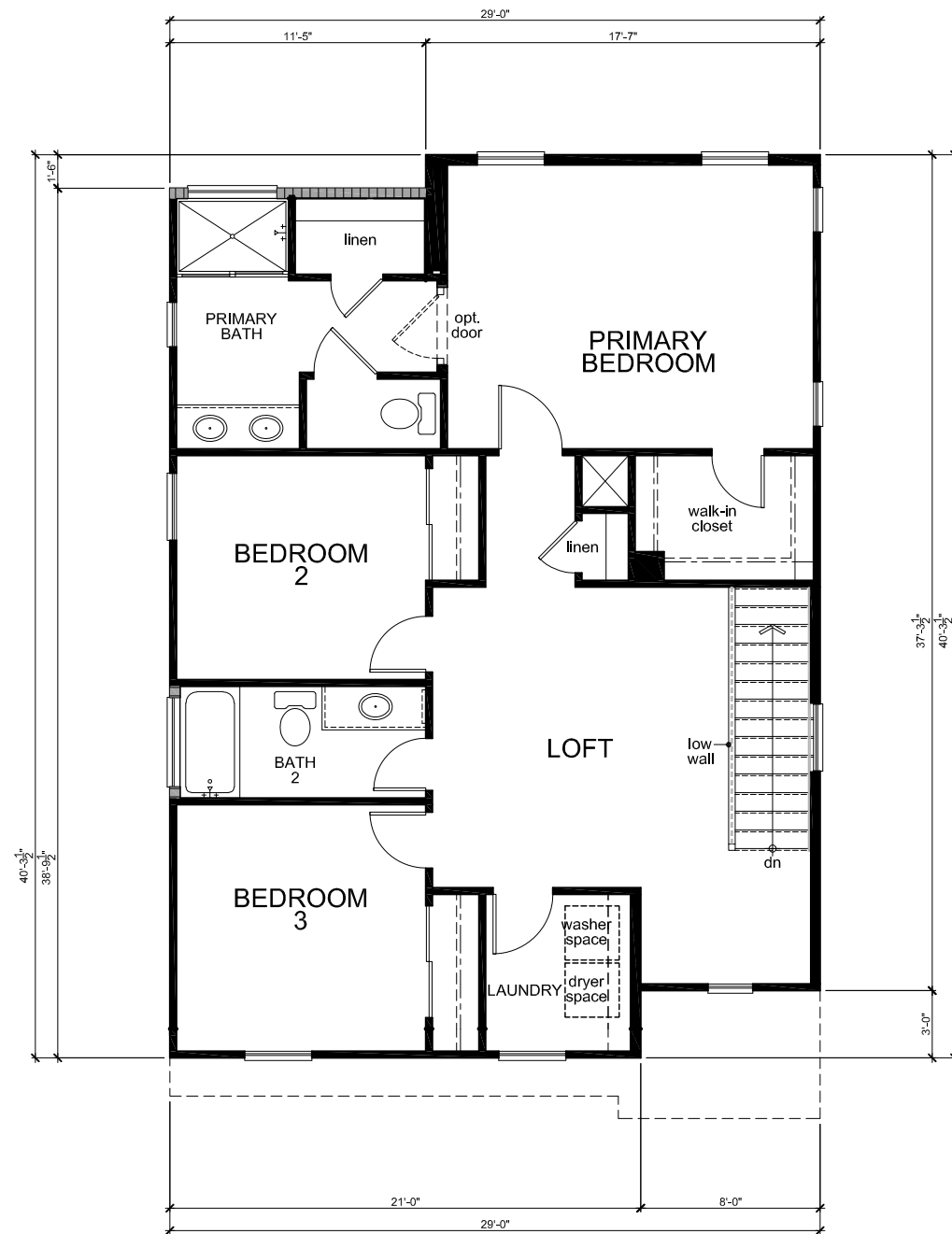

Second Floor Plan 'C'

SQUARE FOOTAGE			
PLAN 229.1791			
FIRST FLOOR AREA	724	SQ. FT.	
SECOND FLOOR AREA	1062	SQ. FT.	
TOTAL AREA	1741	SQ. FT.	
GARAGE AREA	494	SQ. FT.	
PORCH AREA(S)	30	SQ. FT.	
	ELEVATION 'A'	47	SQ. FT.
	ELEVATION 'B'	47	SQ. FT.
	ELEVATION 'C'	47	SQ. FT.

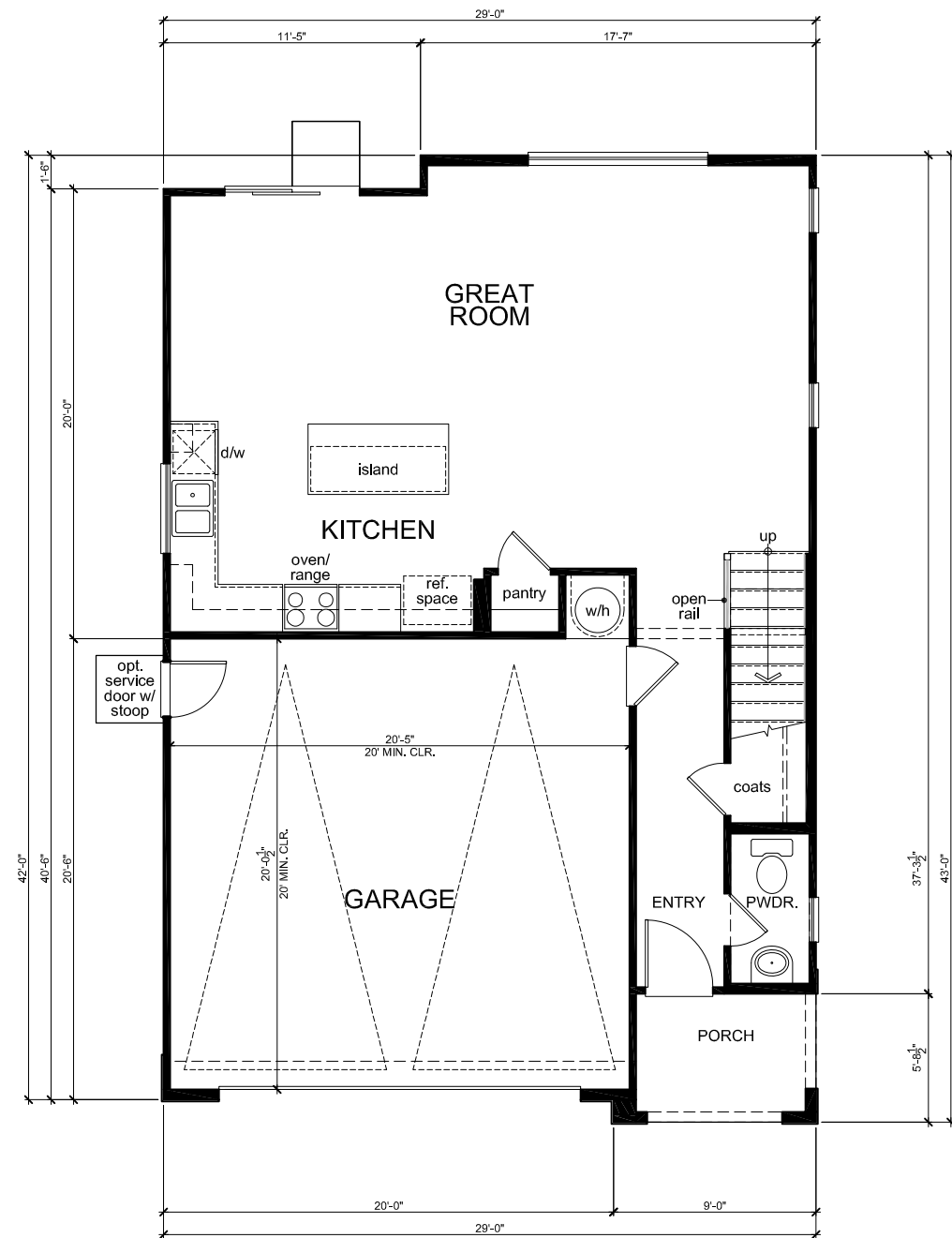

First Floor Plan 'C'

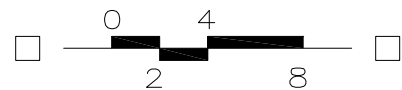



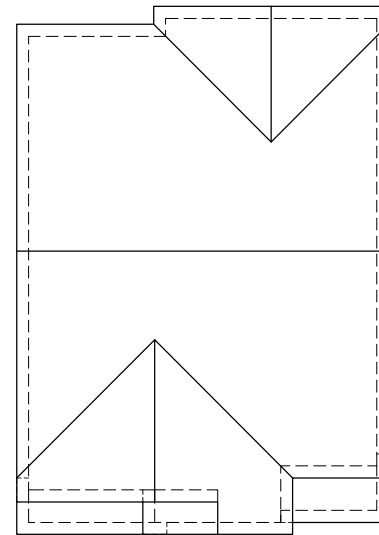

**'A' Spanish**  
4:12

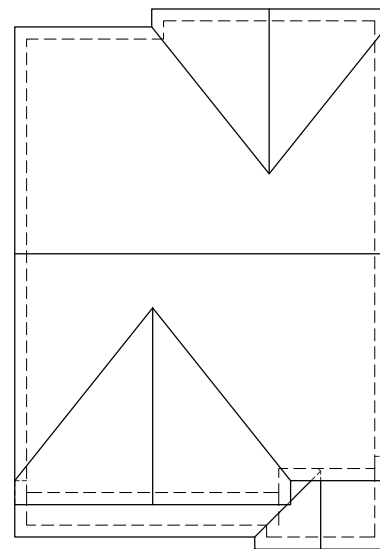

**'B' Craftsman**  
4:12 / 5:12

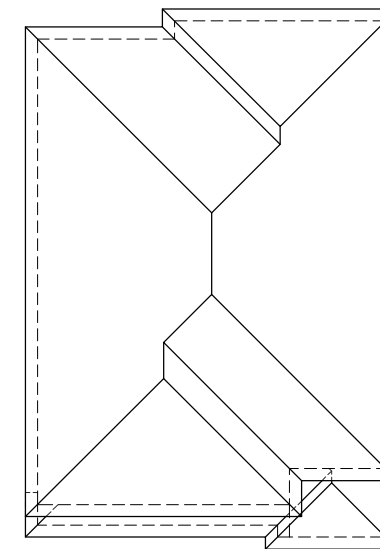

**'C' Italianate**  
4:12

Roof Plans

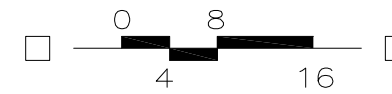

PLAN 1



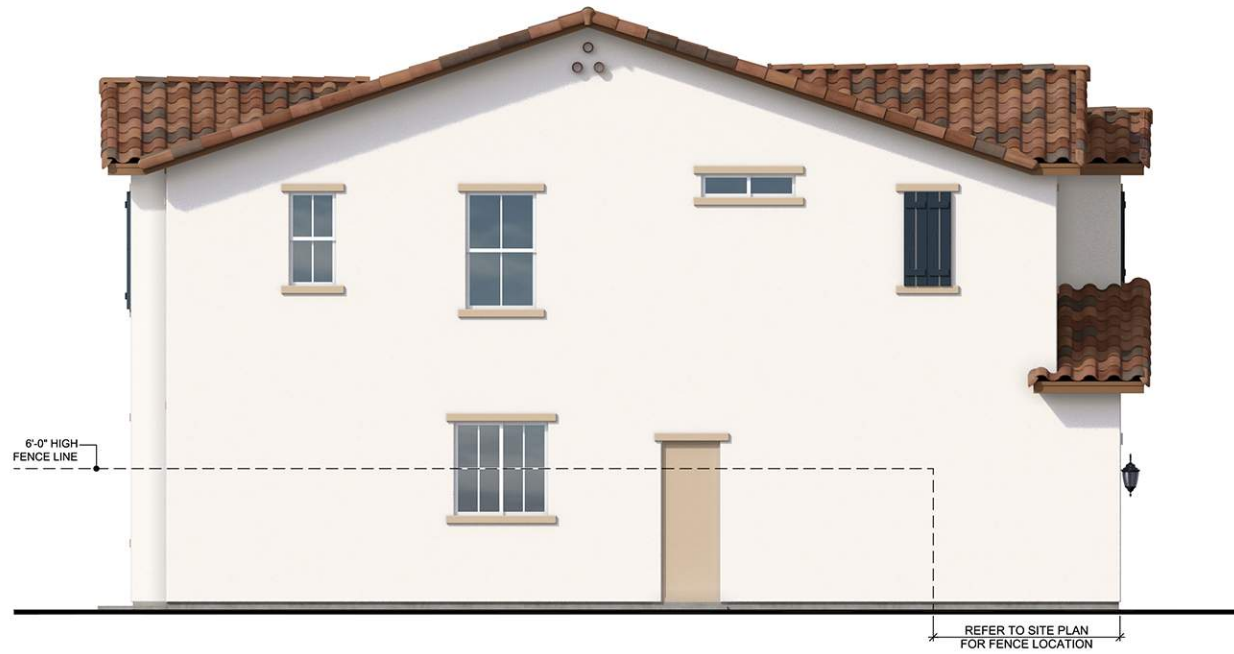

Left Elevation 'A' (Spanish)



Front Elevation 'A' (Spanish)



Right Elevation 'A' (Spanish)



Rear Elevation 'A' (Spanish)

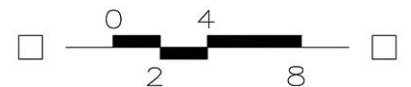

PLAN 1

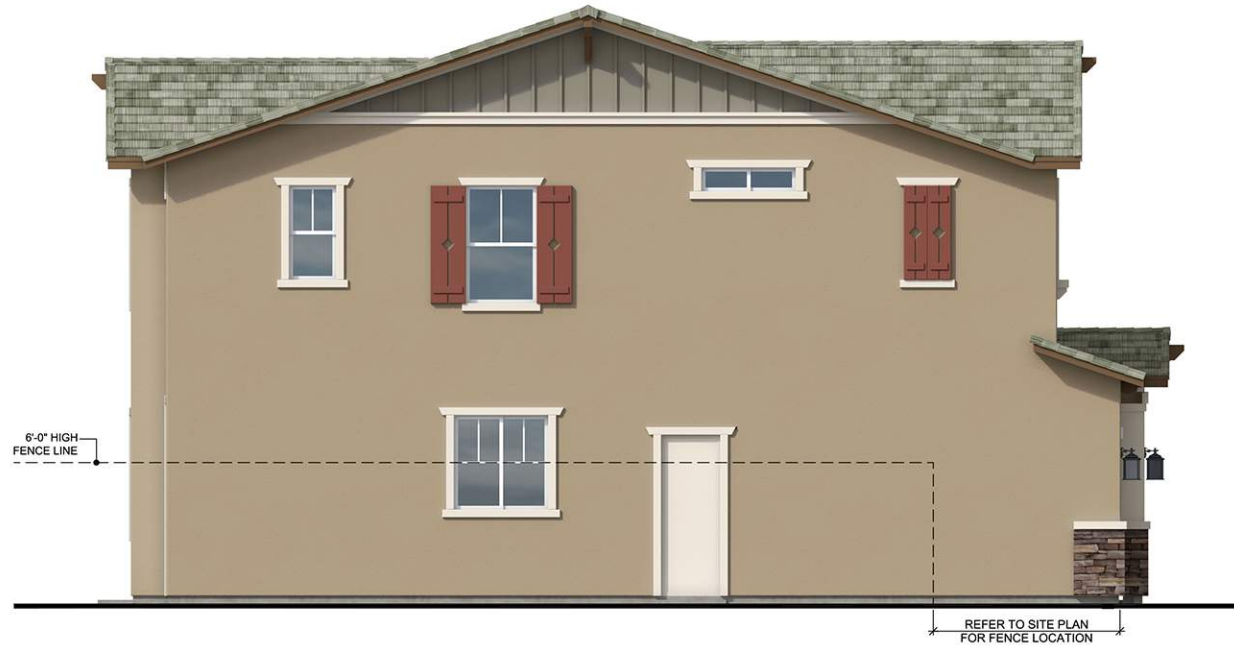

Left Elevation 'B' (Craftsman)



Front Elevation 'B' (Craftsman)



Right Elevation 'B' (Craftsman)



Rear Elevation 'B' (Craftsman)

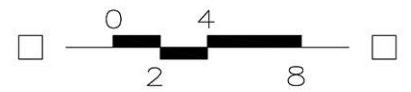

PLAN 1



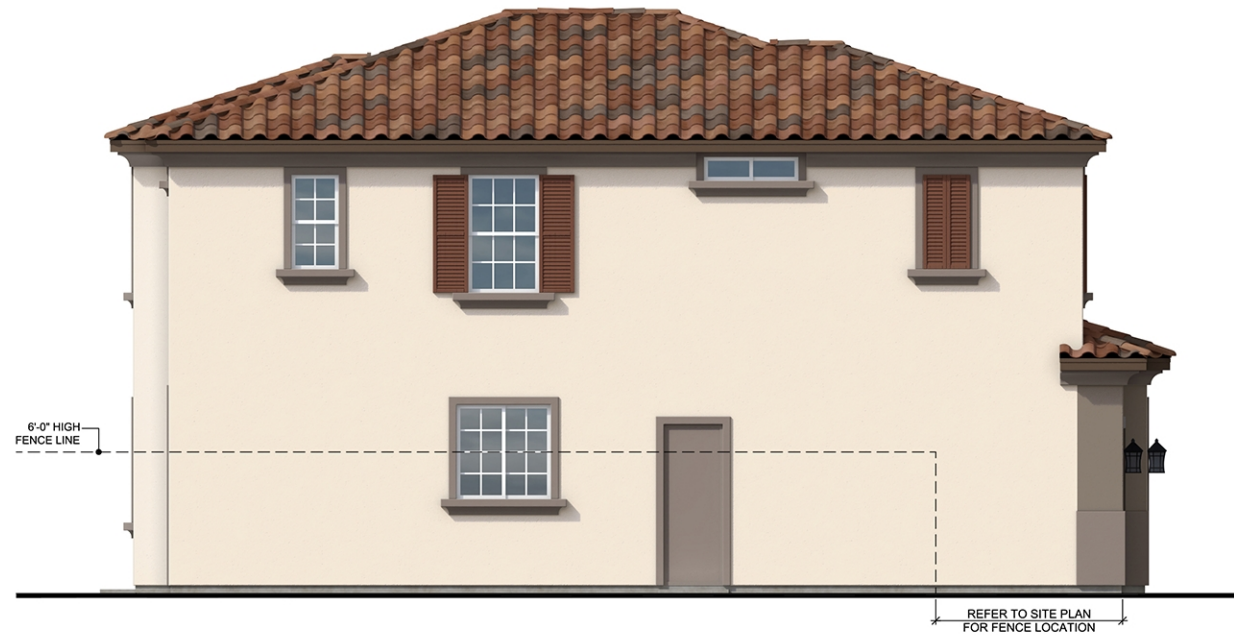

Left Elevation 'C' (Italianate)



Front Elevation 'C' (Italianate)

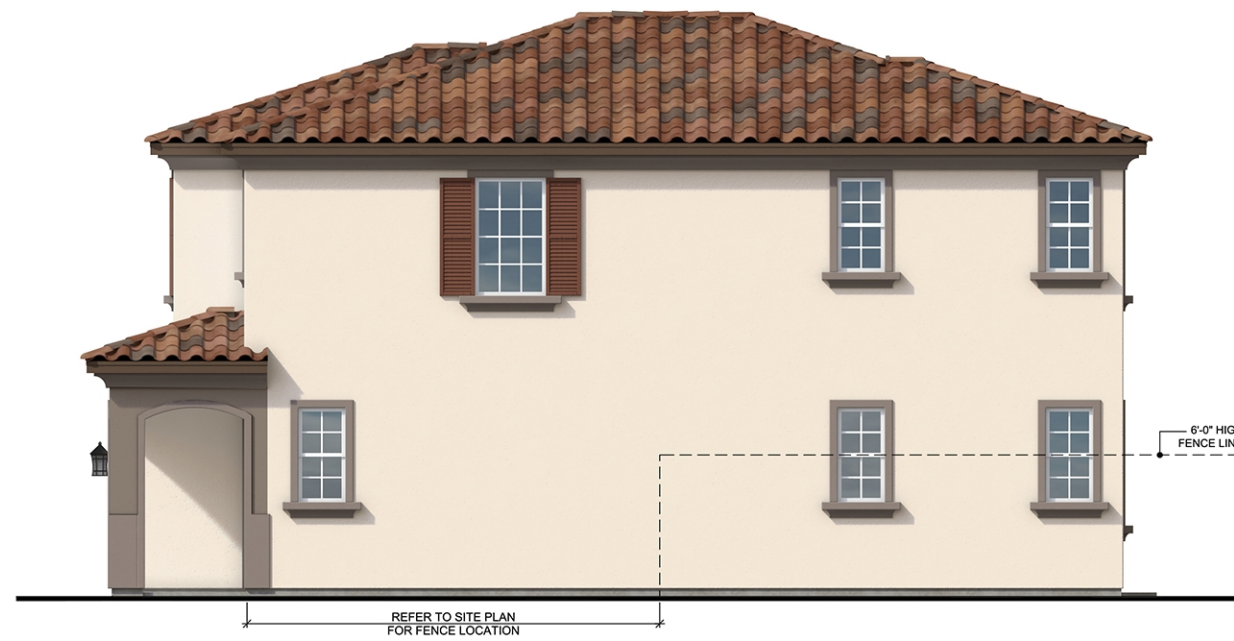

Right Elevation 'C' (Italianate)



Rear Elevation 'C' (Italianate)

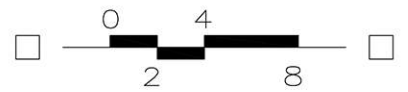

PLAN 1



**ELEVATION LEGEND**

- 1 CONCRETE 'S' TILE ROOFING
- 2 CONCRETE FLAT TILE ROOFING
- 3 WOOD FASCIA BOARD
- 4 STUCCO FINISH (16/20 SAND)
- 5 STUCCO OVER FOAM TRIM
- 6 DECORATIVE STUCCO FINISH OVER FOAM CORBELS/SHAPED FOAM TRIM
- 7 STUCCO COLUMN
- 8 VINYL WINDOW SYSTEM
- 9 COMPOSITE ENTRY DOOR
- 10 METAL SECTIONAL GARAGE DOOR
- 11 DECORATIVE SHUTTERS
- 12 DECORATIVE GABLE END DETAIL
- 13 COACH LIGHTS
- 14 DECORATIVE OUTLOOKERS
- 15 GARAGE WINDOWS
- 16 ADDRESS PLAQUE
- 17 DECORATIVE CLAY PIPE
- 18 STUCCO OVER FOAM POTSHELF
- 19 BOARD AND BATTEN
- 20 WOOD COLUMN
- 21 WOOD POST
- 22 DECORATIVE TILE
- 23 BRICK VENEER
- 24 STONE VENEER
- 25 WROUGHT IRON POTSHELF
- 26 EXPOSED RAFTER TAILS



Elevation 'A' (Spanish)



Elevation 'B' (Craftsman)



Elevation 'C' (Italianate)

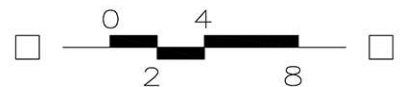

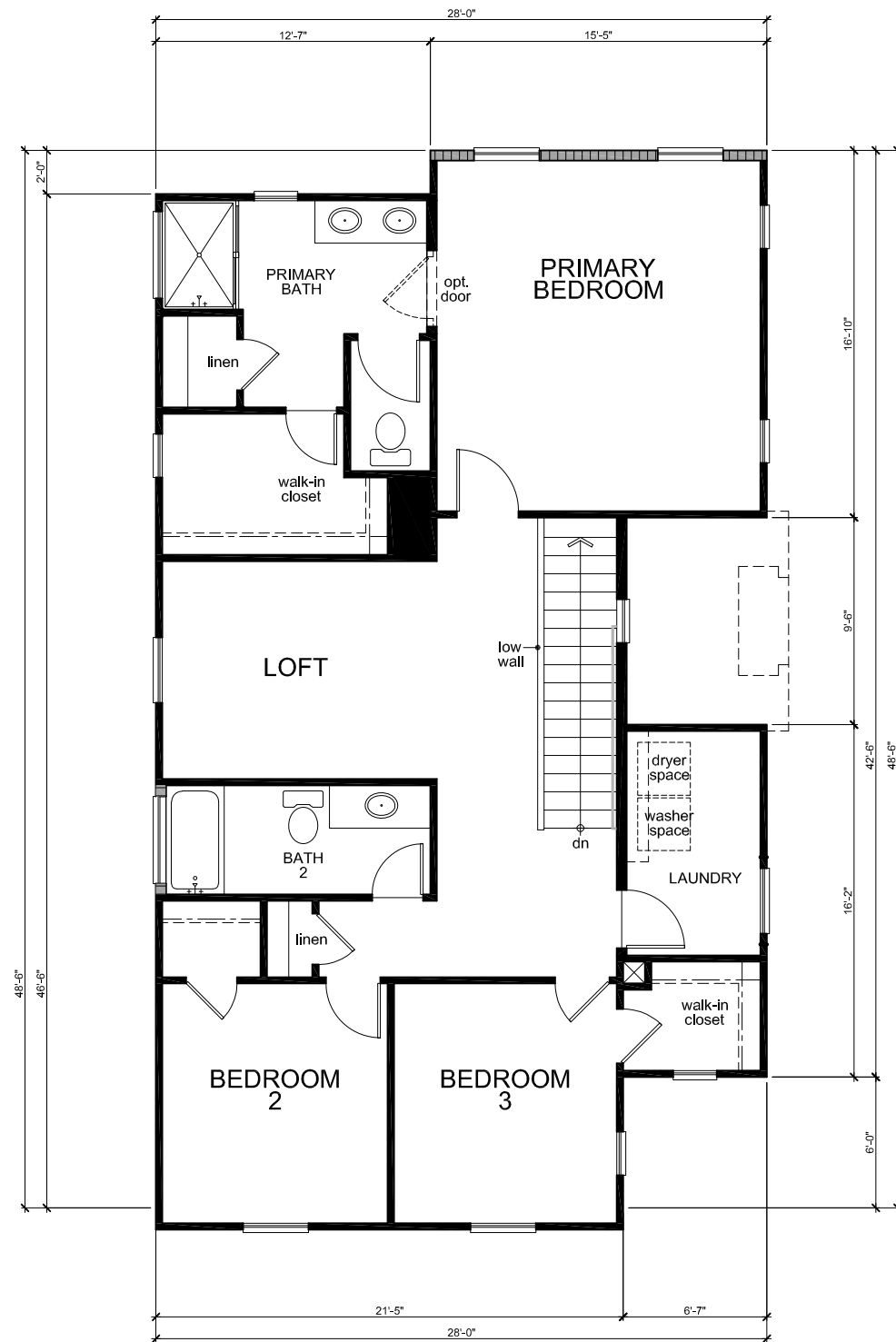

Second Floor Plan 'A'

SQUARE FOOTAGE			
PLAN 228.2056			
FIRST FLOOR AREA	854	SQ. FT.	
SECOND FLOOR AREA	1202	SQ. FT.	
<b>TOTAL AREA</b>	<b>2056</b>	<b>SQ. FT.</b>	
GARAGE AREA	448	SQ. FT.	
PORCH AREA(S)	14	SQ. FT.	
	ELEVATION 'A'	14	SQ. FT.
	ELEVATION 'B'	24	SQ. FT.
	ELEVATION 'C'	14	SQ. FT.

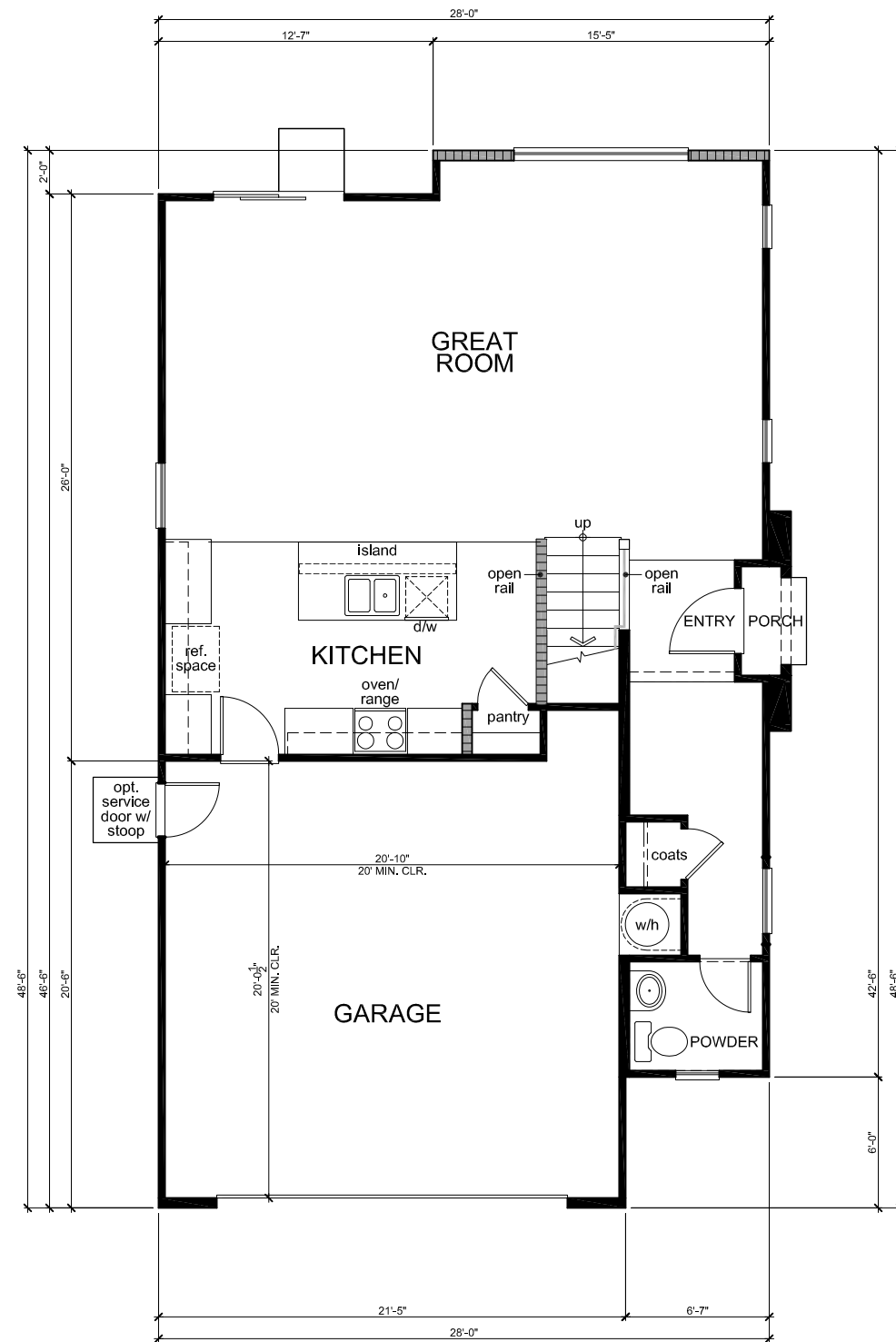

First Floor Plan 'A'

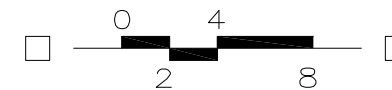



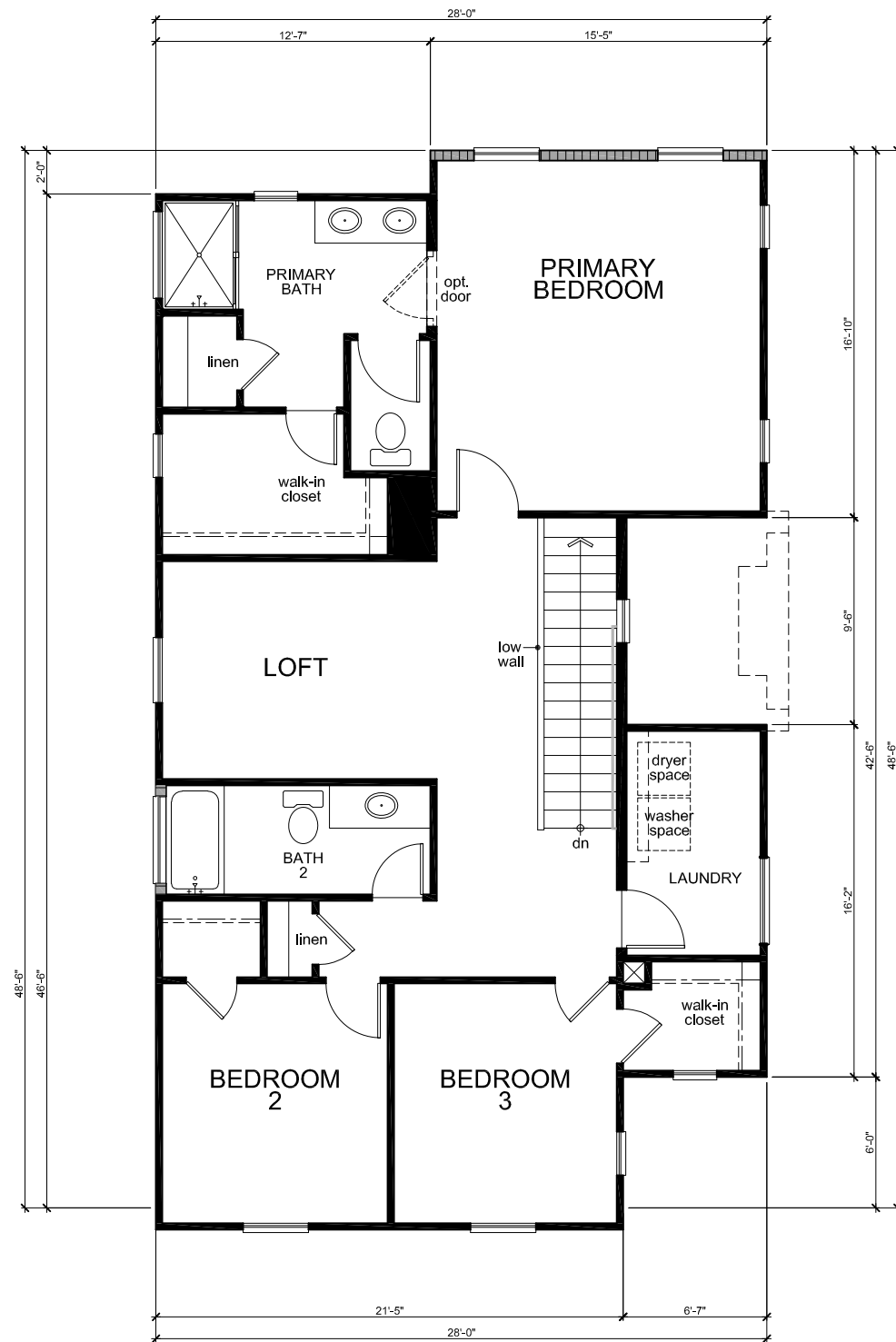

Second Floor Plan 'B'

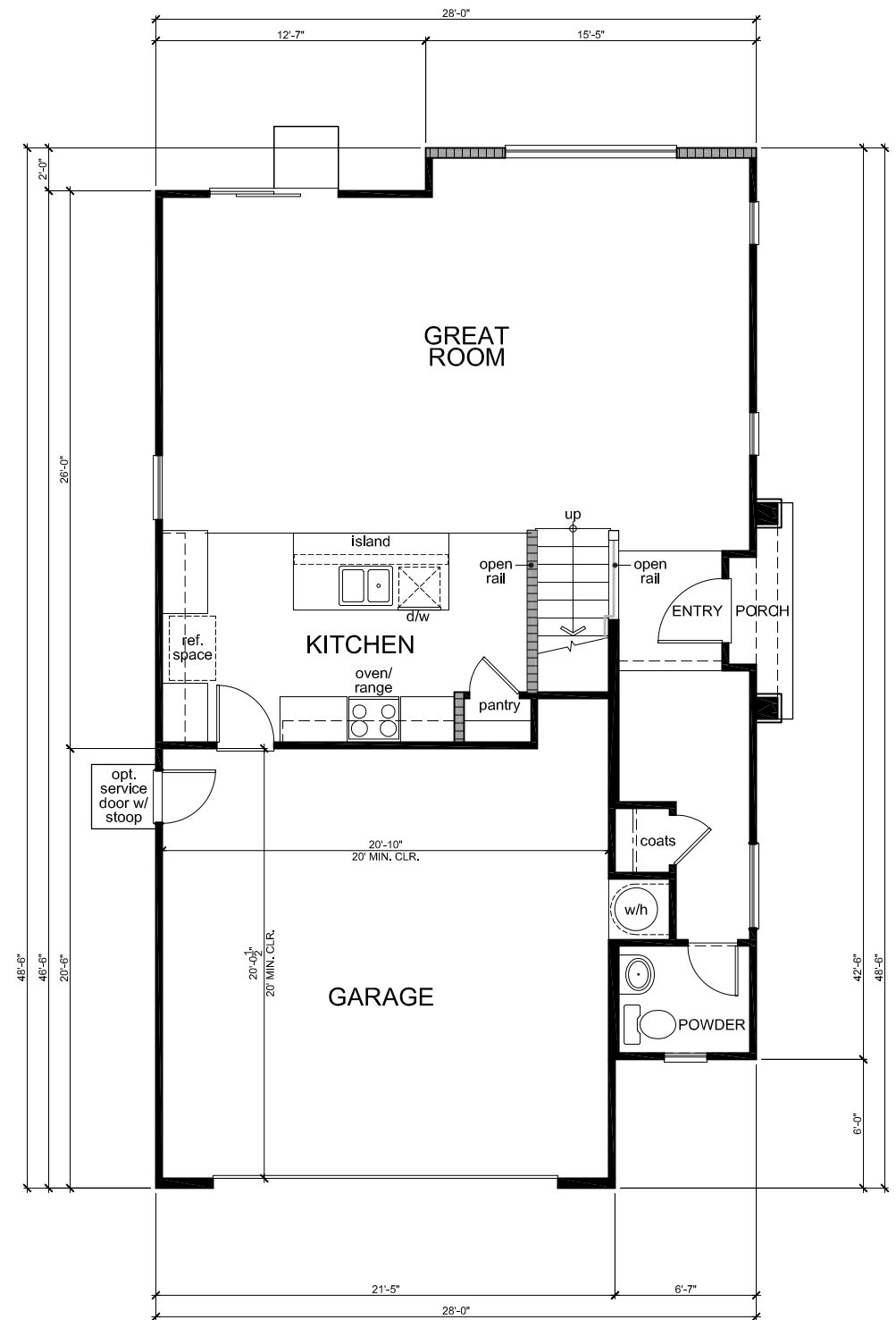

First Floor Plan 'B'

SQUARE FOOTAGE			
PLAN 228.2056			
FIRST FLOOR AREA	854	SQ. FT.	
SECOND FLOOR AREA	1202	SQ. FT.	
<b>TOTAL AREA</b>	<b>2056</b>	<b>SQ. FT.</b>	
GARAGE AREA	448	SQ. FT.	
PORCH AREA(S)	ELEVATION 'A'	14	SQ. FT.
	ELEVATION 'B'	24	SQ. FT.
	ELEVATION 'C'	14	SQ. FT.



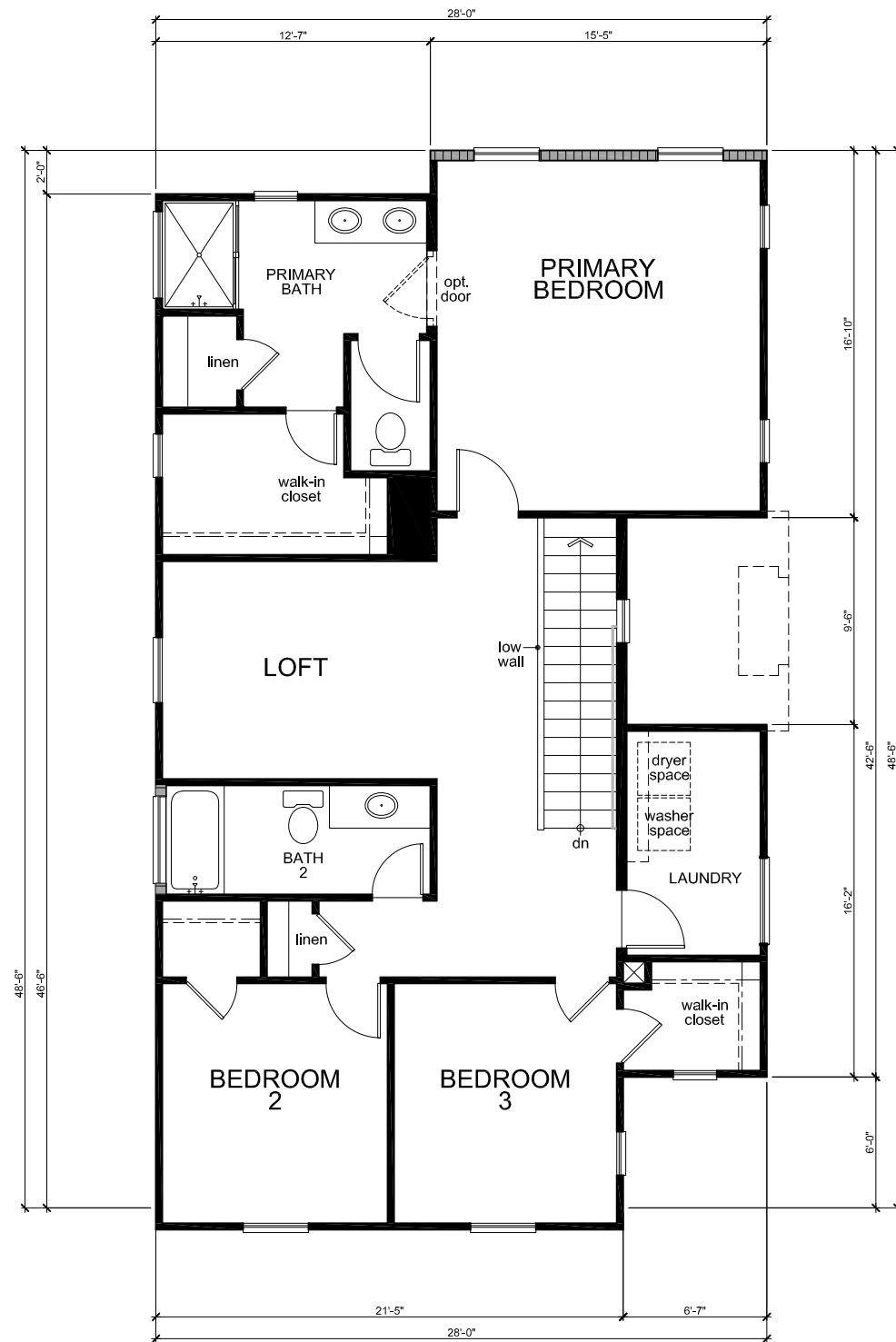

Second Floor Plan 'C'

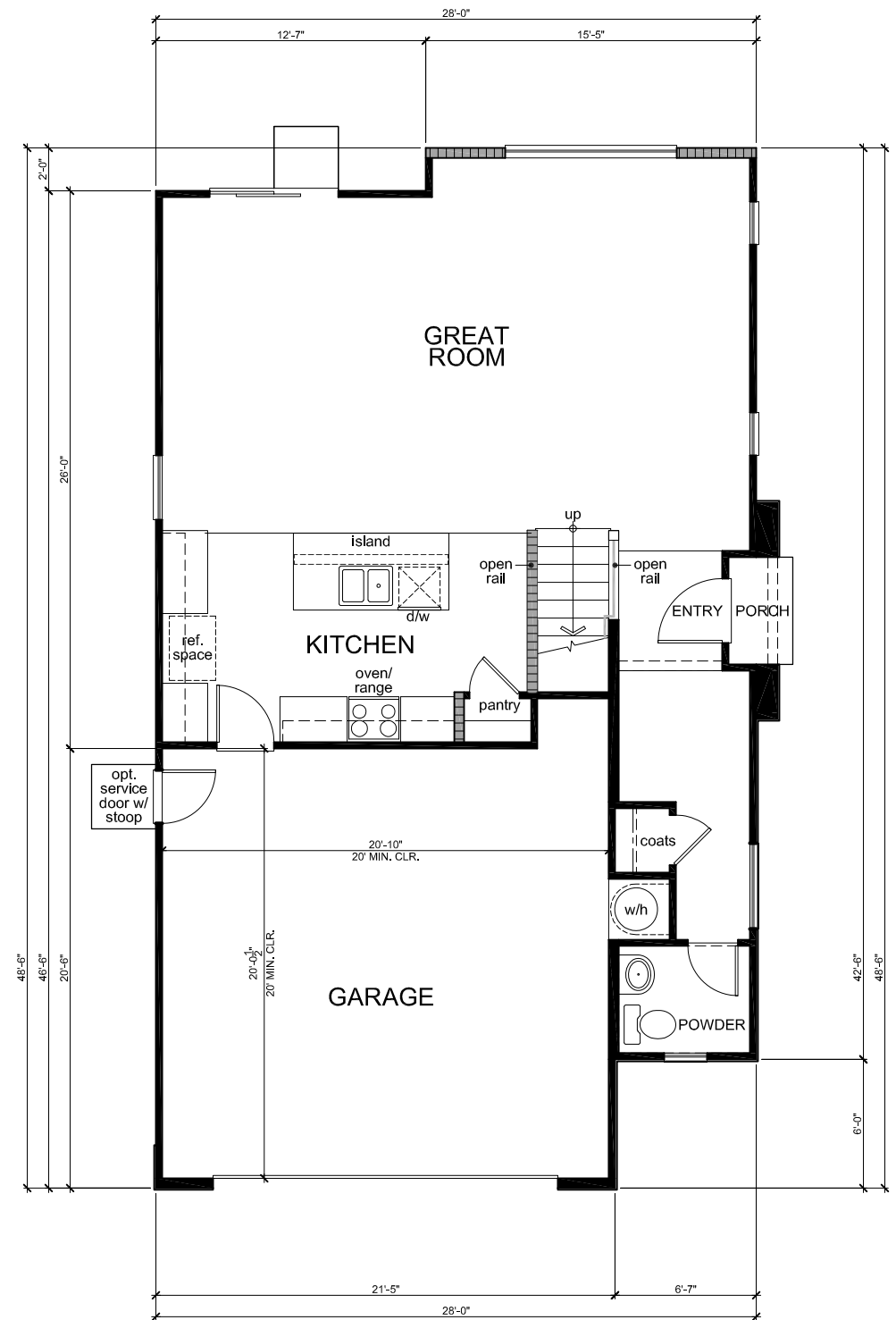

First Floor Plan 'C'

SQUARE FOOTAGE			
PLAN 228.2056			
FIRST FLOOR AREA	854	SQ. FT.	
SECOND FLOOR AREA	1202	SQ. FT.	
<b>TOTAL AREA</b>	<b>2056</b>	<b>SQ. FT.</b>	
GARAGE AREA	448	SQ. FT.	
PORCH AREA(S)	14	SQ. FT.	ELEVATION 'A'
	24	SQ. FT.	ELEVATION 'B'
	14	SQ. FT.	ELEVATION 'C'



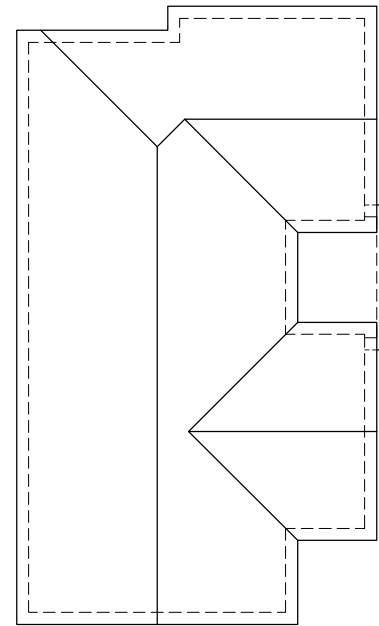

**'A' Spanish**  
4:12

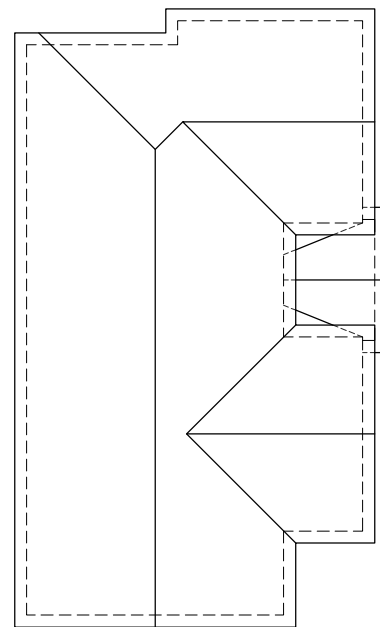

**'B' Craftsman**  
4:12 / 5:12

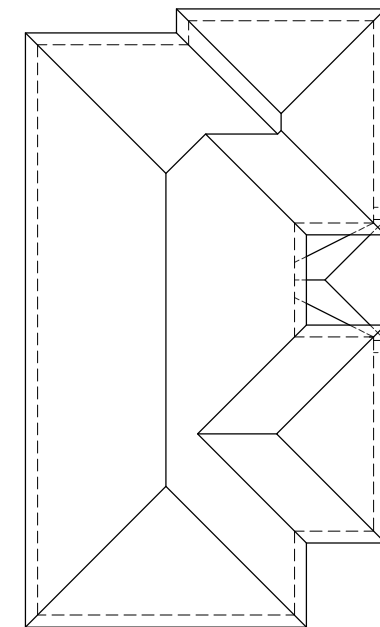

**'C' Italianate**  
4:12

Roof Plans

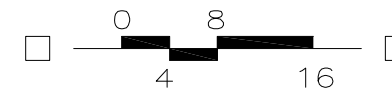



Rear Elevation 'A' (Spanish)



Left Elevation 'A' (Spanish)



Front Elevation 'A' (Spanish)



Right Elevation 'A' (Spanish)

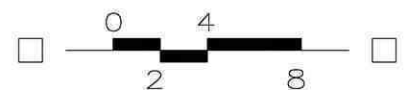



Rear Elevation 'B' (Craftsman)



Left Elevation 'B' (Craftsman)



Front Elevation 'B' (Craftsman)



Right Elevation 'B' (Craftsman)

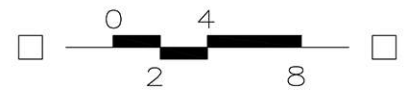

PLAN 2



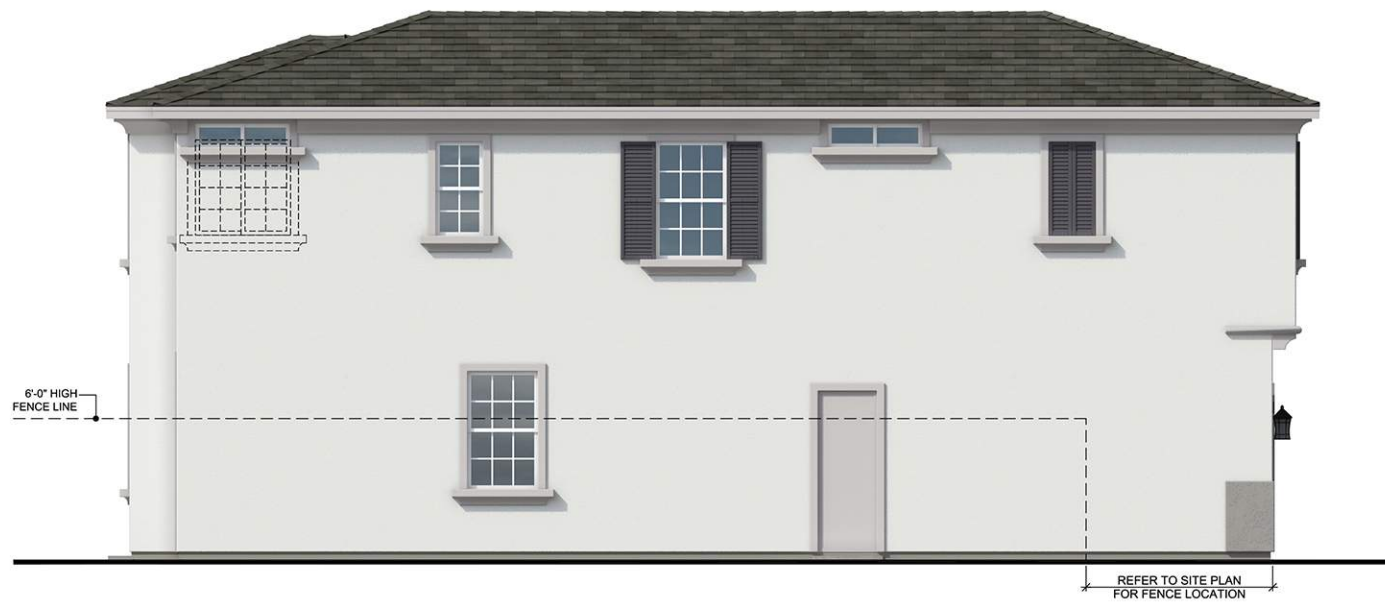

Rear Elevation 'C' (Italianate)



Left Elevation 'C' (Italianate)



Front Elevation 'C' (Italianate)



Right Elevation 'C' (Italianate)

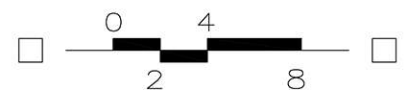

PLAN 2



**ELEVATION LEGEND**

- 1 CONCRETE 'S' TILE ROOFING
- 2 CONCRETE FLAT TILE ROOFING
- 3 WOOD FASCIA BOARD
- 4 STUCCO FINISH (16/20 SAND)
- 5 STUCCO OVER FOAM TRIM
- 6 DECORATIVE STUCCO FINISH OVER FOAM CORBELS/SHAPED FOAM TRIM
- 7 STUCCO COLUMN
- 8 VINYL WINDOW SYSTEM
- 9 COMPOSITE ENTRY DOOR
- 10 METAL SECTIONAL GARAGE DOOR
- 11 DECORATIVE SHUTTERS
- 12 DECORATIVE GABLE END DETAIL
- 13 COACH LIGHTS
- 14 DECORATIVE OUTLOOKERS
- 15 GARAGE WINDOWS
- 16 ADDRESS PLAQUE
- 17 DECORATIVE CLAY PIPE
- 18 STUCCO OVER FOAM POTSHELF
- 19 BOARD AND BATTEN
- 20 WOOD COLUMN
- 21 WOOD POST
- 22 DECORATIVE TILE
- 23 BRICK VENEER
- 24 STONE VENEER
- 25 WROUGHT IRON POTSHELF
- 26 EXPOSED RAFTER TAILS



Elevation 'A' (Spanish)

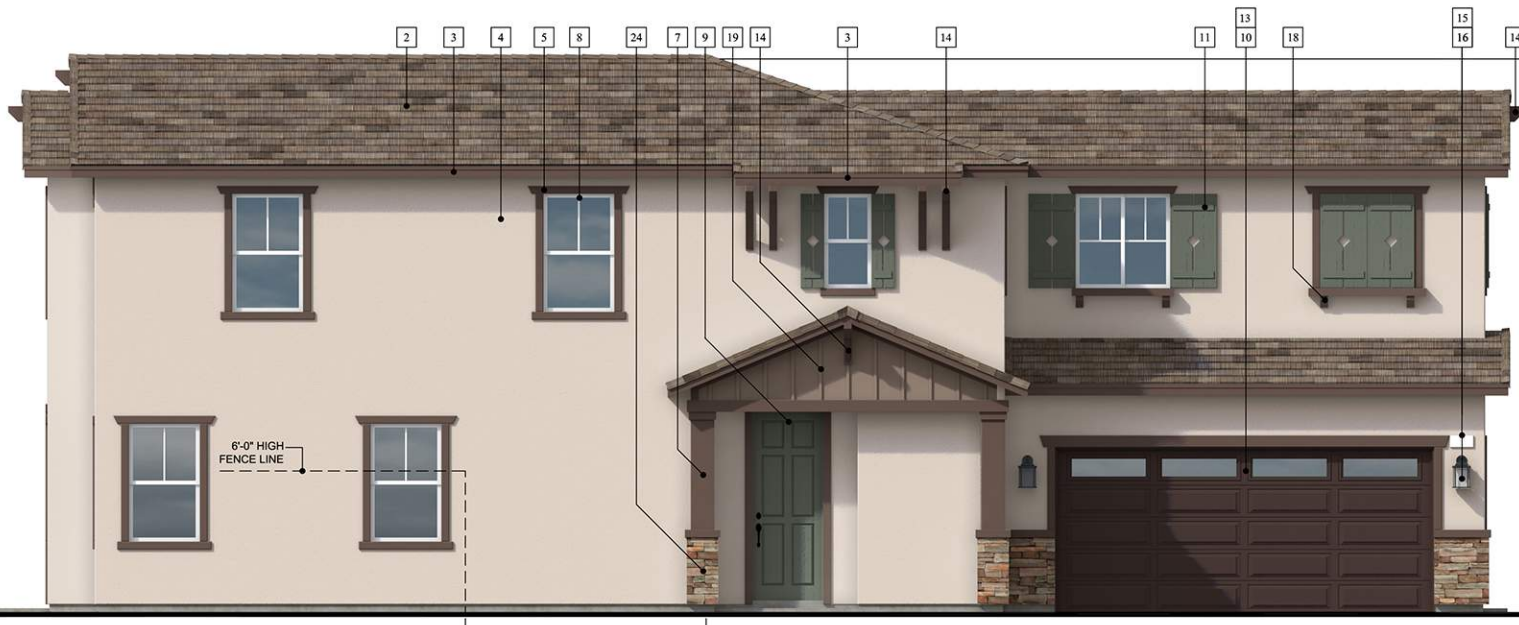

Elevation 'B' (Craftsman)



Elevation 'C' (Italianate)

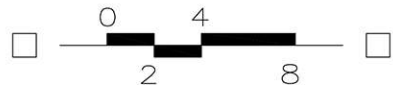

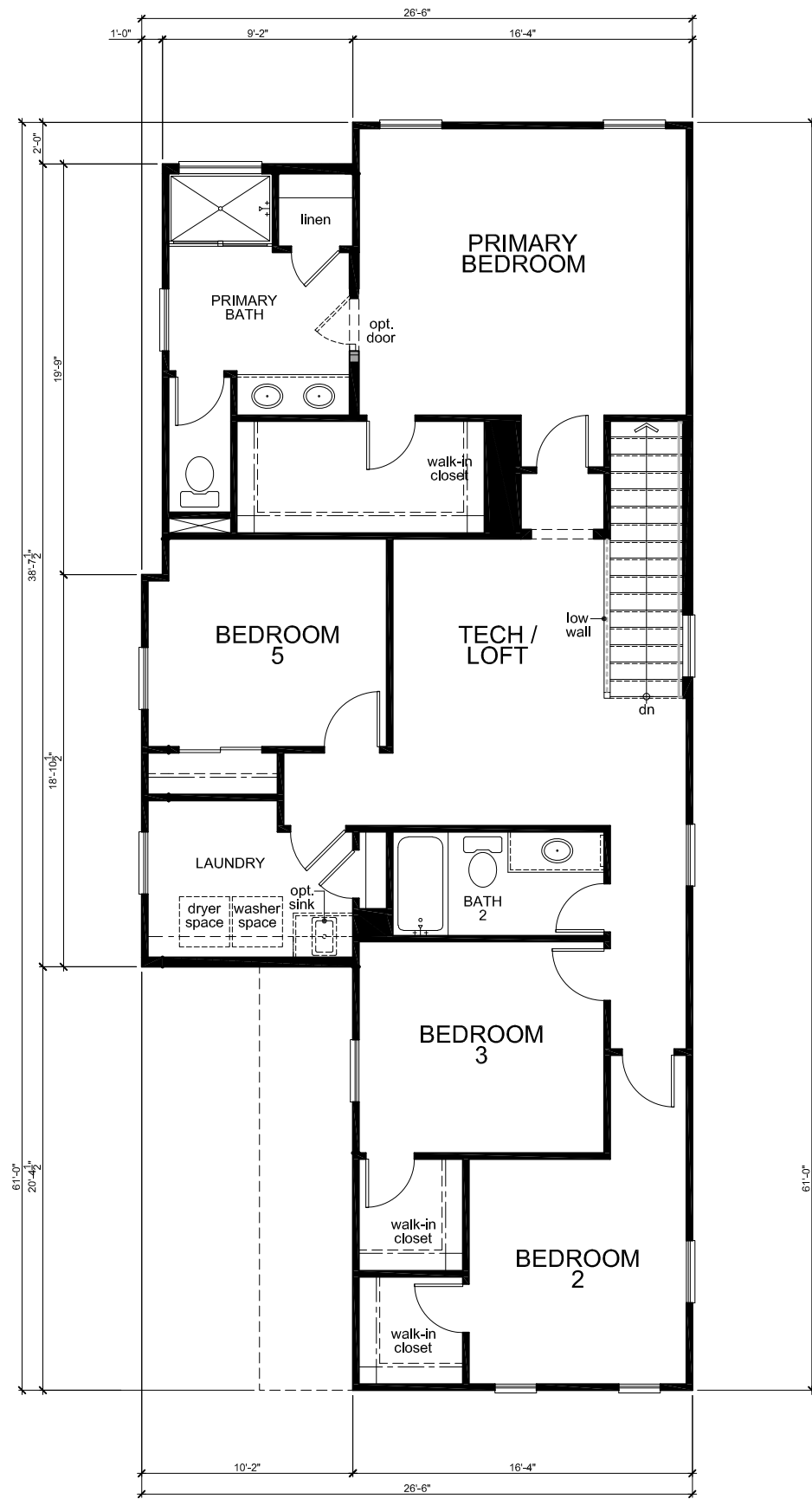

Second Floor Plan 'A'

SQUARE FOOTAGE			
PLAN 226.2320			
FIRST FLOOR AREA	1003	SQ. FT.	
SECOND FLOOR AREA	1917	SQ. FT.	
<b>TOTAL AREA</b>	<b>2920</b>	<b>SQ. FT.</b>	
GARAGE AREA	496	SQ. FT.	
PORCH AREA(S)	14	SQ. FT.	
	ELEVATION 'A'	14	SQ. FT.
	ELEVATION 'B'	33	SQ. FT.
	ELEVATION 'C'	14	SQ. FT.

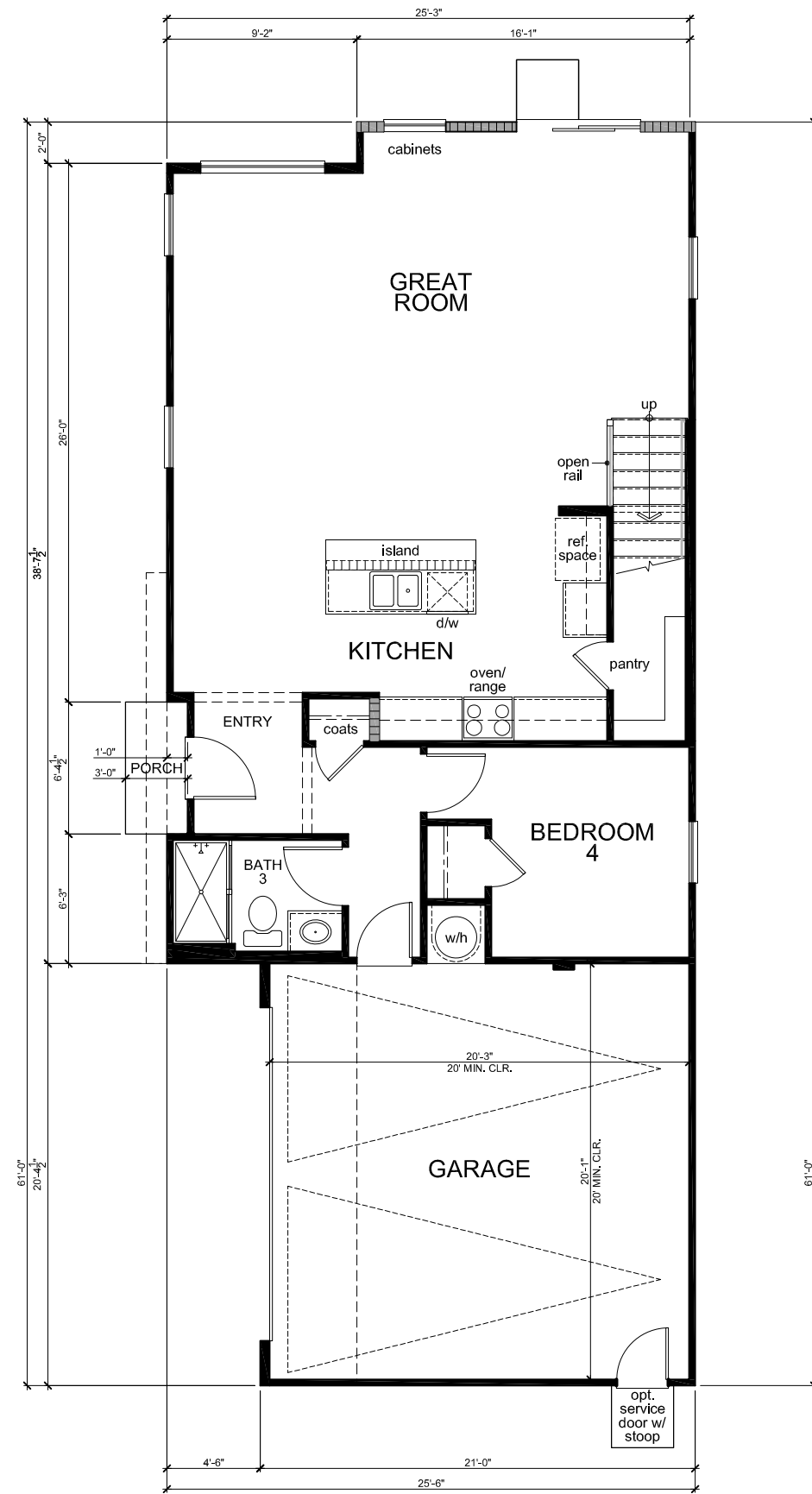

First Floor Plan 'A'

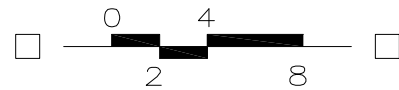

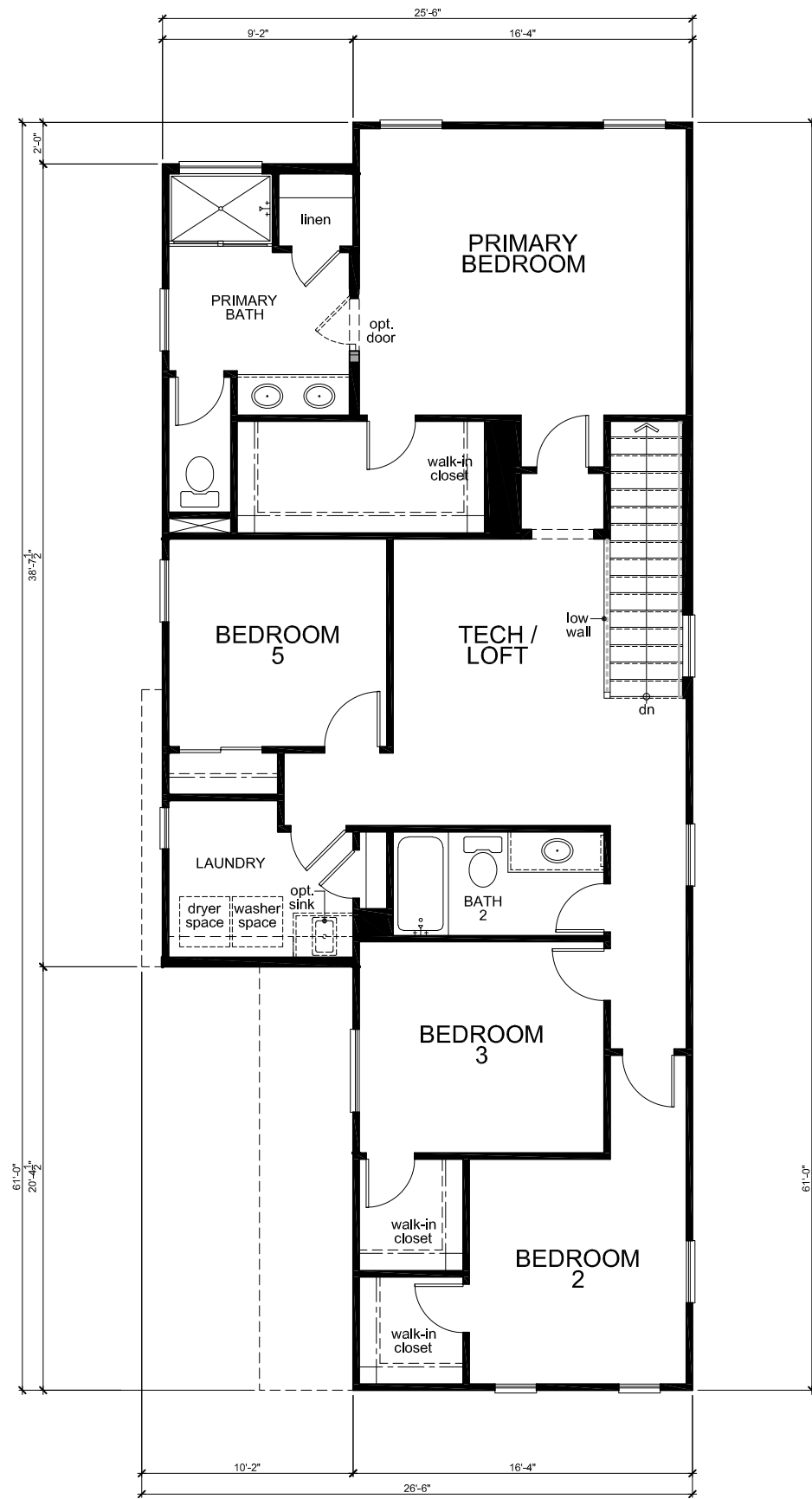

Second Floor Plan 'B'

SQUARE FOOTAGE			
PLAN 226.2320			
FIRST FLOOR AREA	1003	SQ. FT.	
SECOND FLOOR AREA	1317	SQ. FT.	
<b>TOTAL AREA</b>	<b>2320</b>	<b>SQ. FT.</b>	
GARAGE AREA	496	SQ. FT.	
PORCH AREA(S)	14	SQ. FT.	
	ELEVATION 'A'	33	SQ. FT.
	ELEVATION 'B'	14	SQ. FT.
	ELEVATION 'C'		

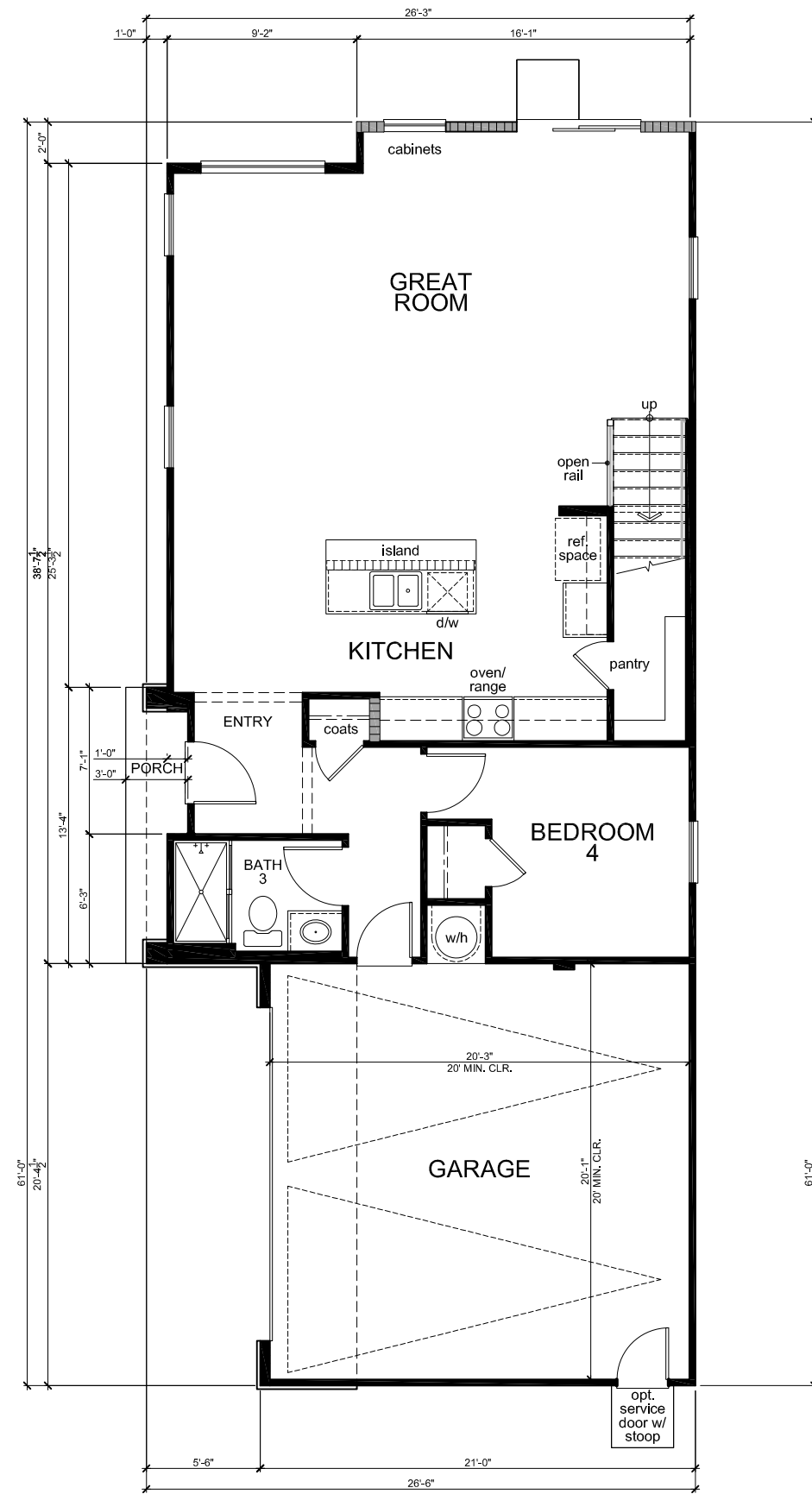

First Floor Plan 'B'

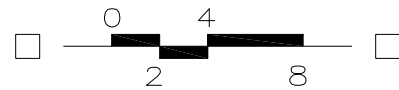

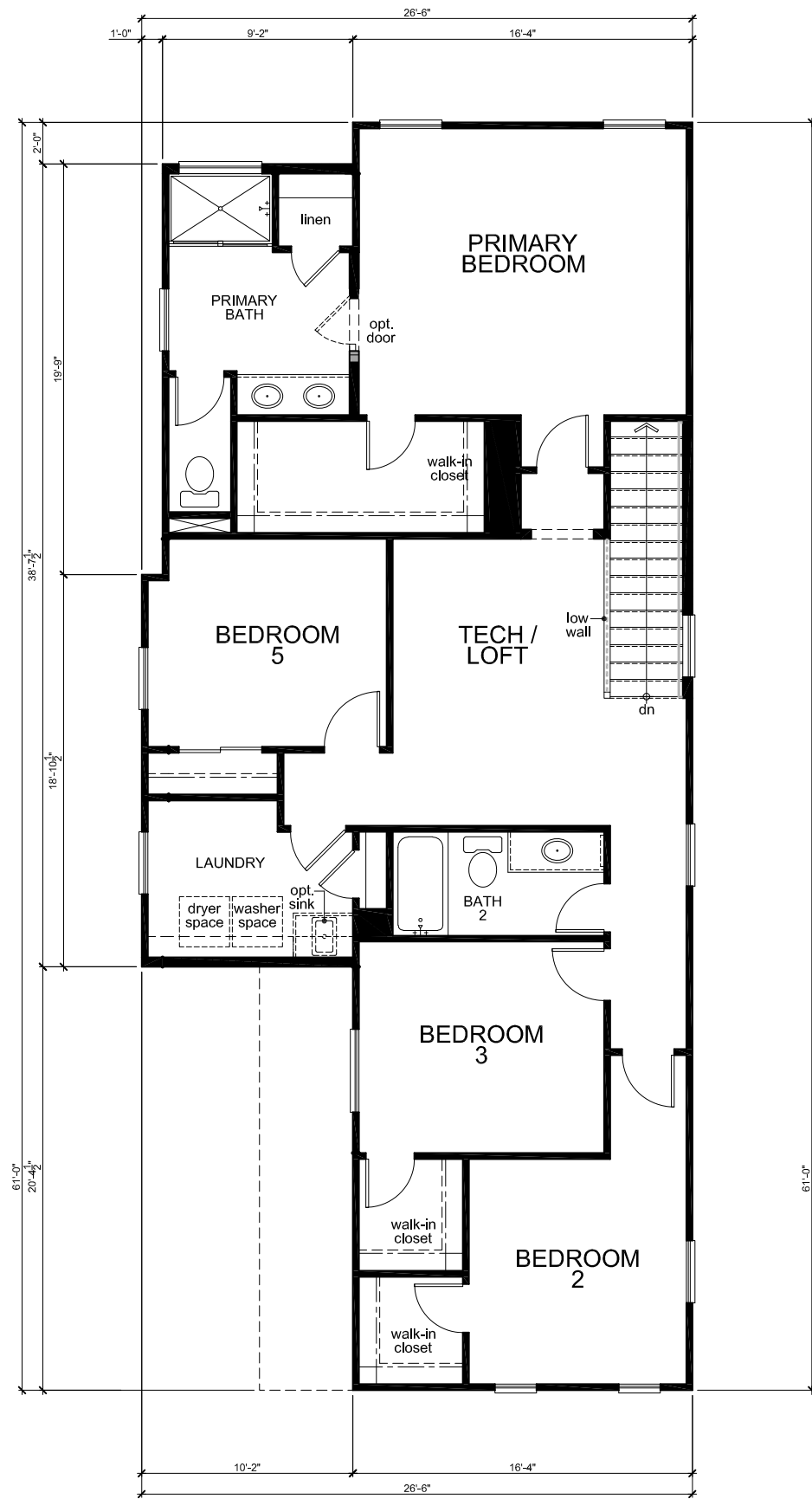

Second Floor Plan 'C'

SQUARE FOOTAGE			
PLAN 226.2320			
FIRST FLOOR AREA	1003	SQ. FT.	
SECOND FLOOR AREA	1917	SQ. FT.	
<b>TOTAL AREA</b>	<b>2920</b>	<b>SQ. FT.</b>	
GARAGE AREA	496	SQ. FT.	
PORCH AREA(S)	14	SQ. FT.	
	ELEVATION 'A'	14	SQ. FT.
	ELEVATION 'B'	33	SQ. FT.
	ELEVATION 'C'	14	SQ. FT.

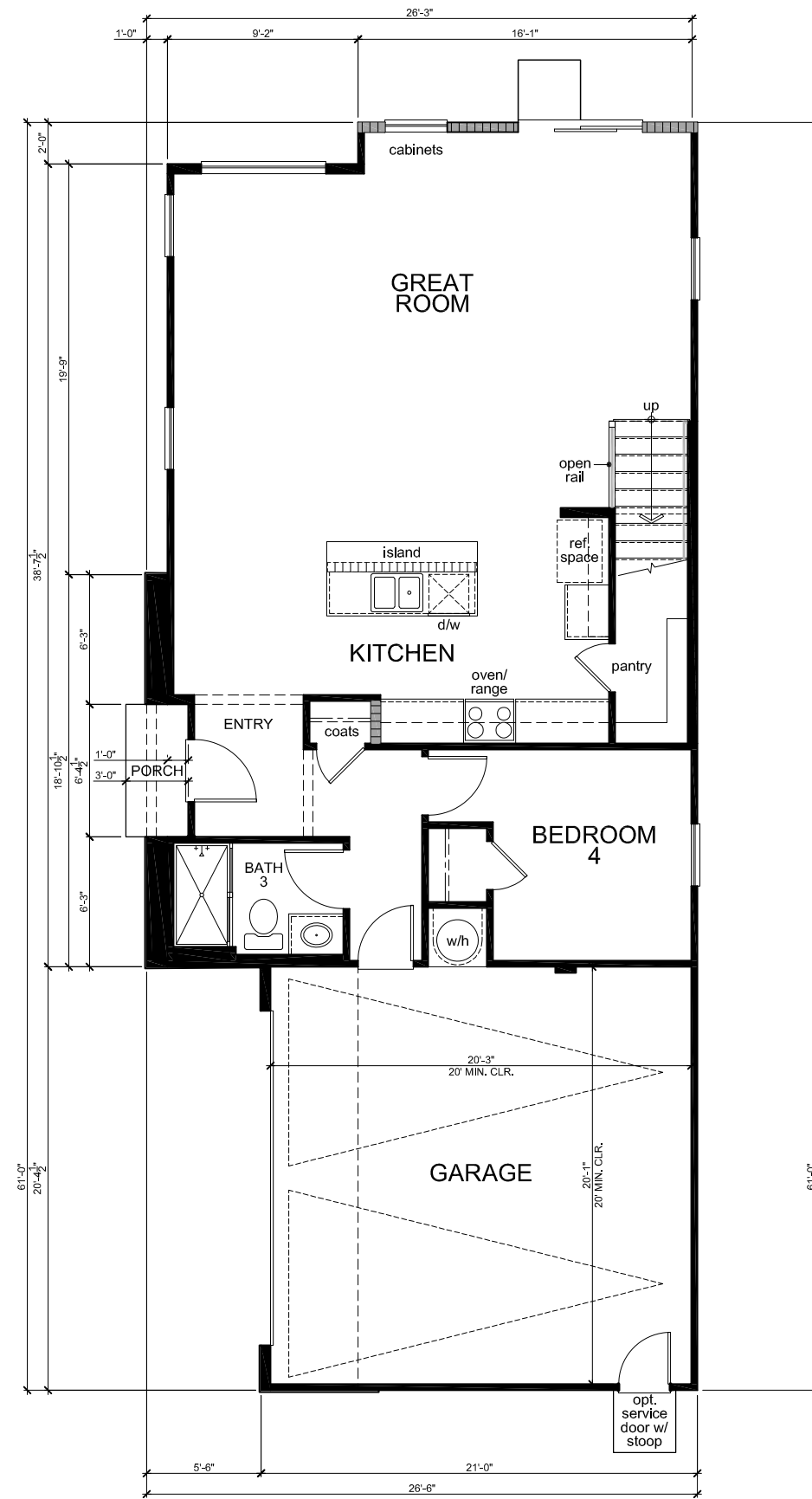

First Floor Plan 'C'

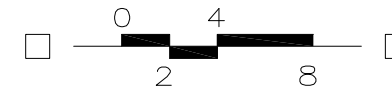

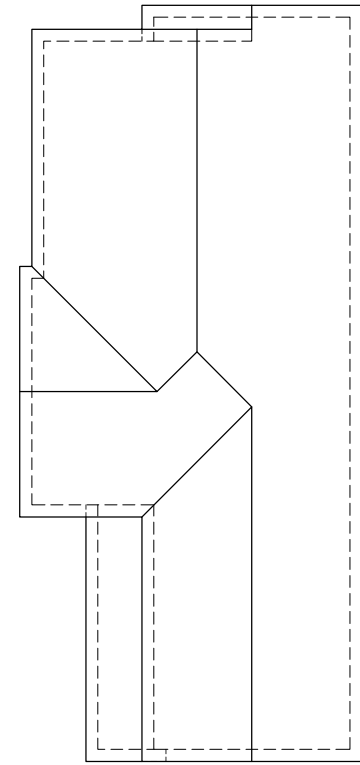

**'A' Spanish**  
4:12

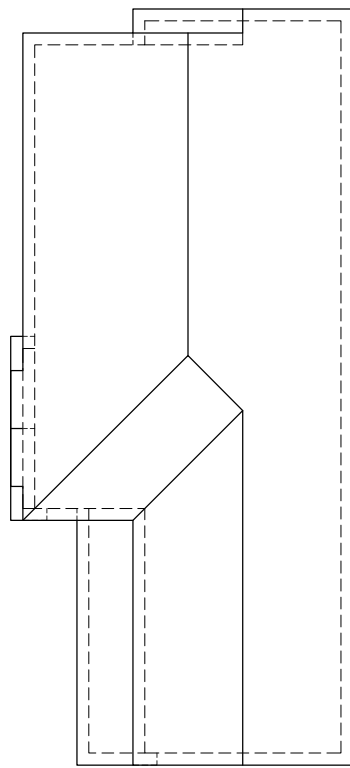

**'B' Craftsman**  
4:12 / 5:12

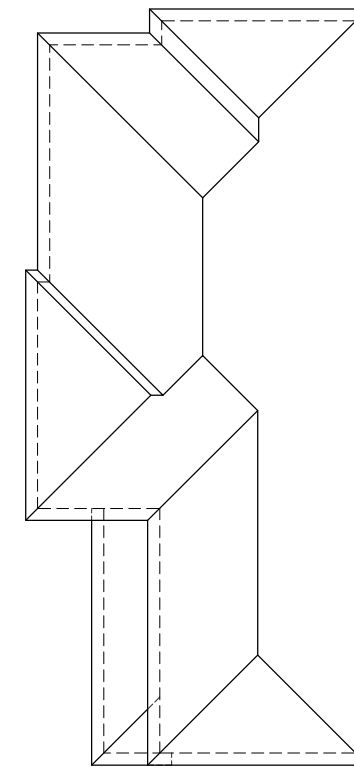

**'C' Italianate**  
4:12

Roof Plans

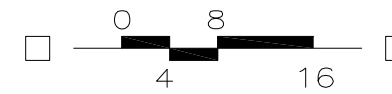

PLAN 3







Front Elevation 'A' (Spanish)

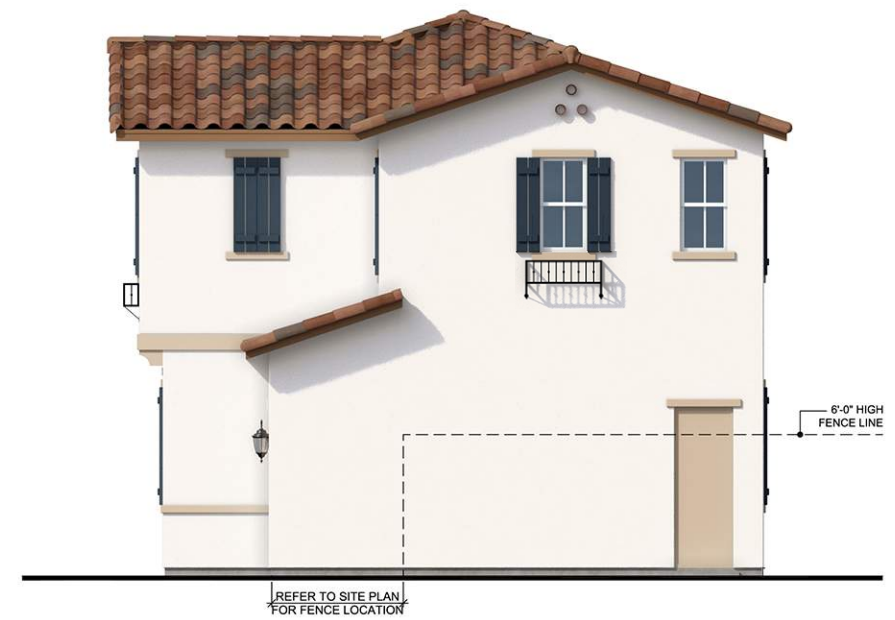

Right Elevation 'A' (Spanish)



Rear Elevation 'A' (Spanish)



Left Elevation 'A' (Spanish)

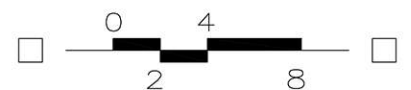





Front Elevation 'B' (Craftsman)



Right Elevation 'B' (Craftsman)



Rear Elevation 'B' (Craftsman)



Left Elevation 'B' (Craftsman)

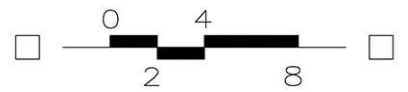

PLAN 3



Front Elevation 'C' (Italianate)



Right Elevation 'C' (Italianate)

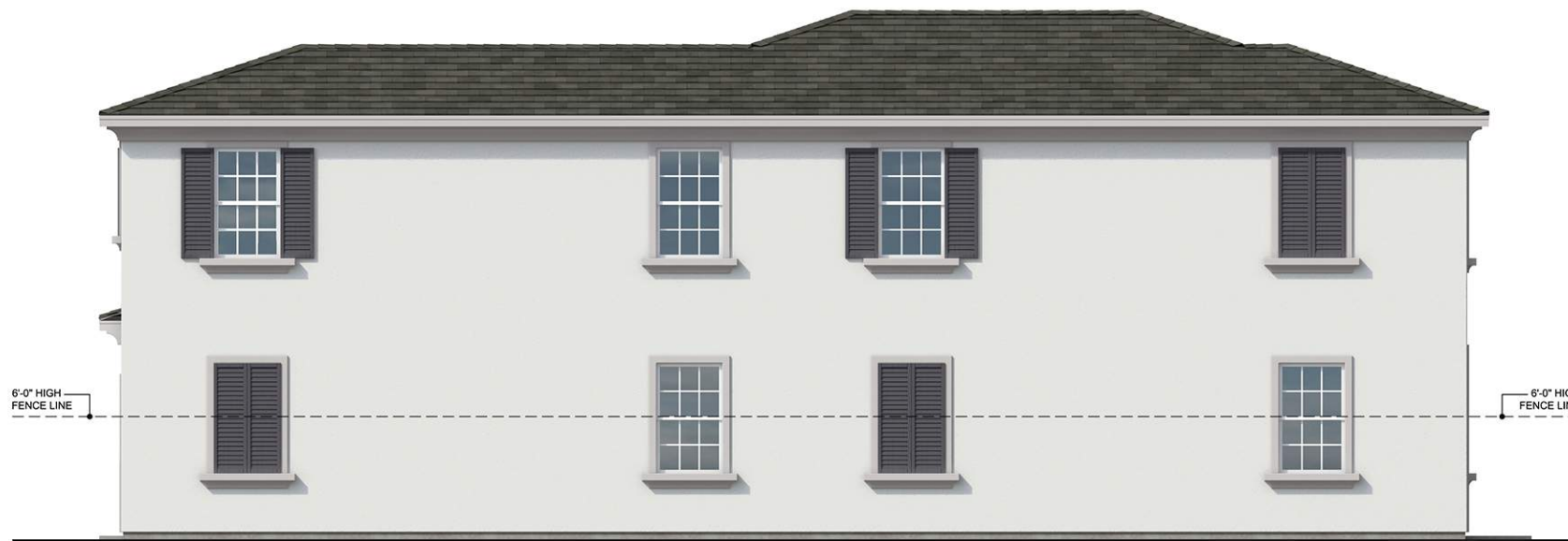

Rear Elevation 'C' (Italianate)



Left Elevation 'C' (Italianate)

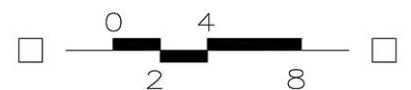

PLAN 3



**ELEVATION LEGEND**

- 1 CONCRETE 'S' TILE ROOFING
- 2 CONCRETE FLAT TILE ROOFING
- 3 WOOD FASCIA BOARD
- 4 STUCCO FINISH (16/20 SAND)
- 5 STUCCO OVER FOAM TRIM
- 6 DECORATIVE STUCCO FINISH OVER FOAM CORBELS/SHAPED FOAM TRIM
- 7 STUCCO COLUMN
- 8 VINYL WINDOW SYSTEM
- 9 COMPOSITE ENTRY DOOR
- 10 METAL SECTIONAL GARAGE DOOR
- 11 DECORATIVE SHUTTERS
- 12 DECORATIVE GABLE END DETAIL
- 13 COACH LIGHTS
- 14 DECORATIVE OUTLOOKERS
- 15 GARAGE WINDOWS
- 16 ADDRESS PLAQUE
- 17 DECORATIVE CLAY PIPE
- 18 STUCCO OVER FOAM POTSHELF
- 19 BOARD AND BATTEN
- 20 WOOD COLUMN
- 21 WOOD POST
- 22 DECORATIVE TILE
- 23 BRICK VENEER
- 24 STONE VENEER
- 25 WROUGHT IRON POTSHELF
- 26 EXPOSED RAFTER TAILS



Elevation 'A' (Spanish)



Elevation 'B' (Craftsman)



Elevation 'C' (Italianate)

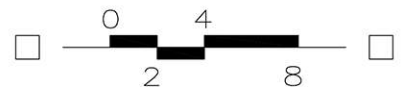

PLAN 1

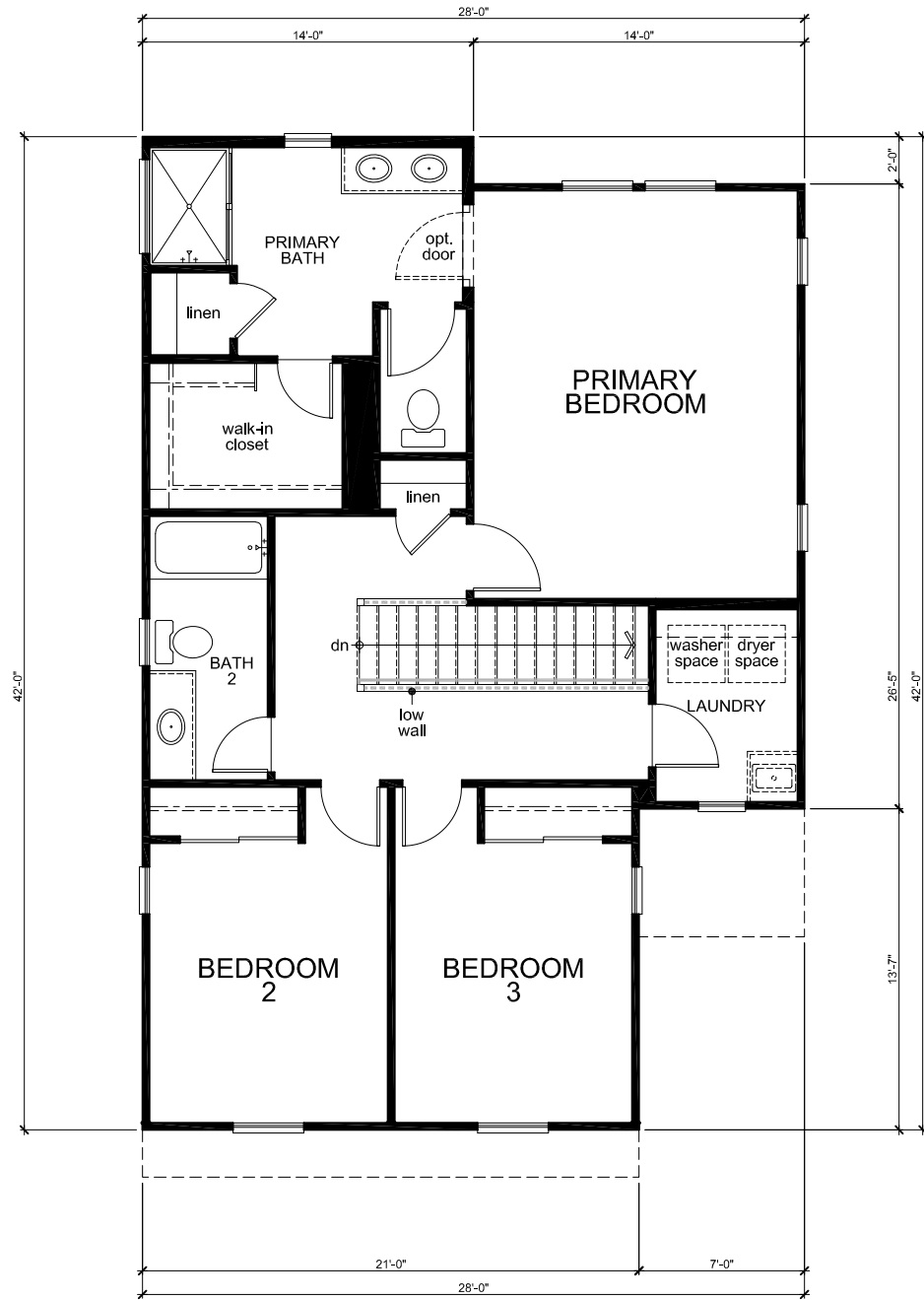

Second Floor Plan 'A'

SQUARE FOOTAGE			
PLAN 228.1677			
FIRST FLOOR AREA	665	SQ. FT.	
SECOND FLOOR AREA	1012	SQ. FT.	
TOTAL AREA	1677	SQ. FT.	
GARAGE AREA	440	SQ. FT.	
PORCH AREA(S)			
	ELEVATION 'A'	38	SQ. FT.
	ELEVATION 'B'	38	SQ. FT.
	ELEVATION 'C'	38	SQ. FT.

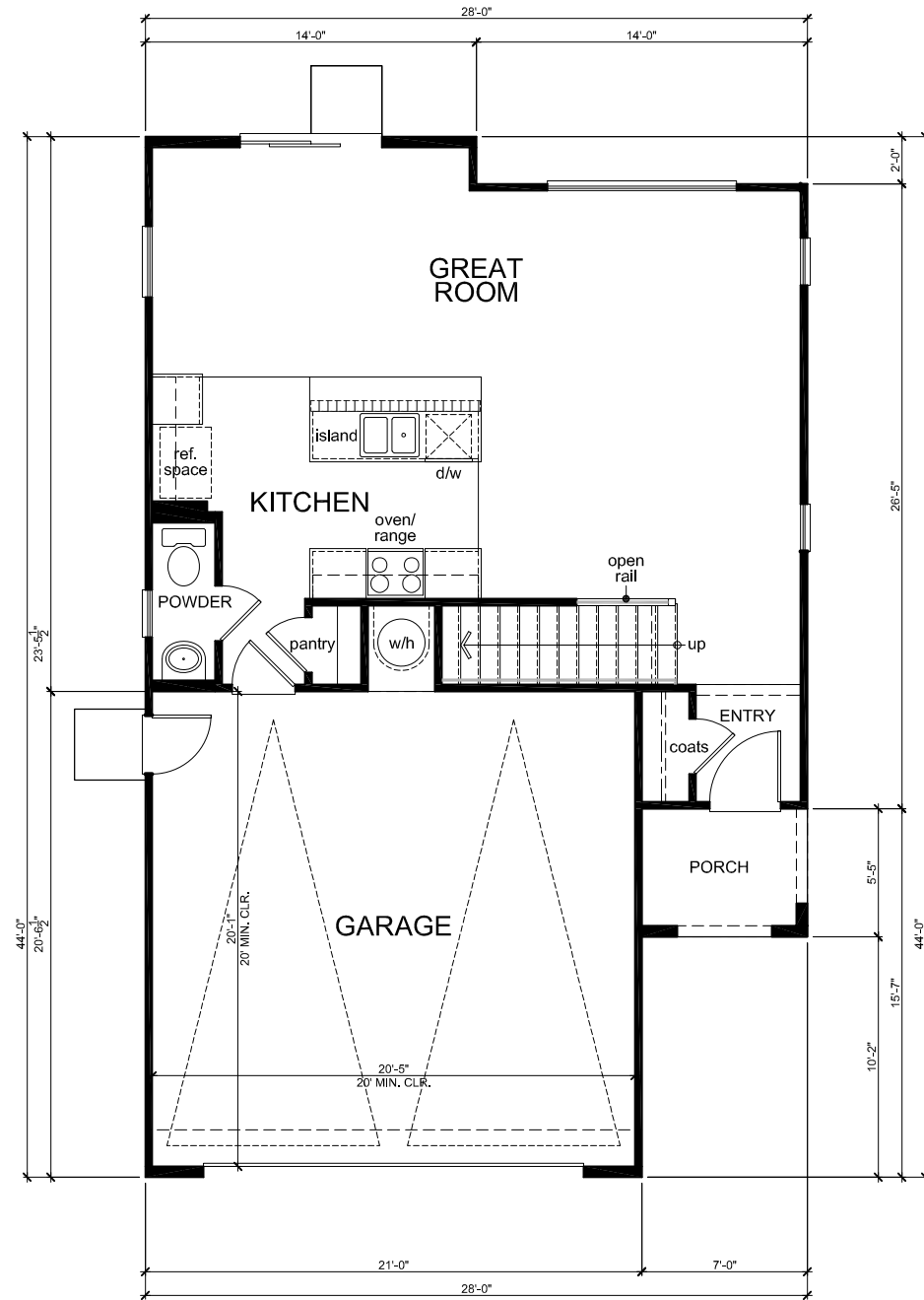

First Floor Plan 'A'

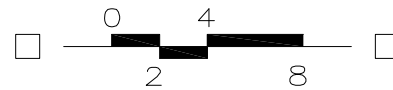

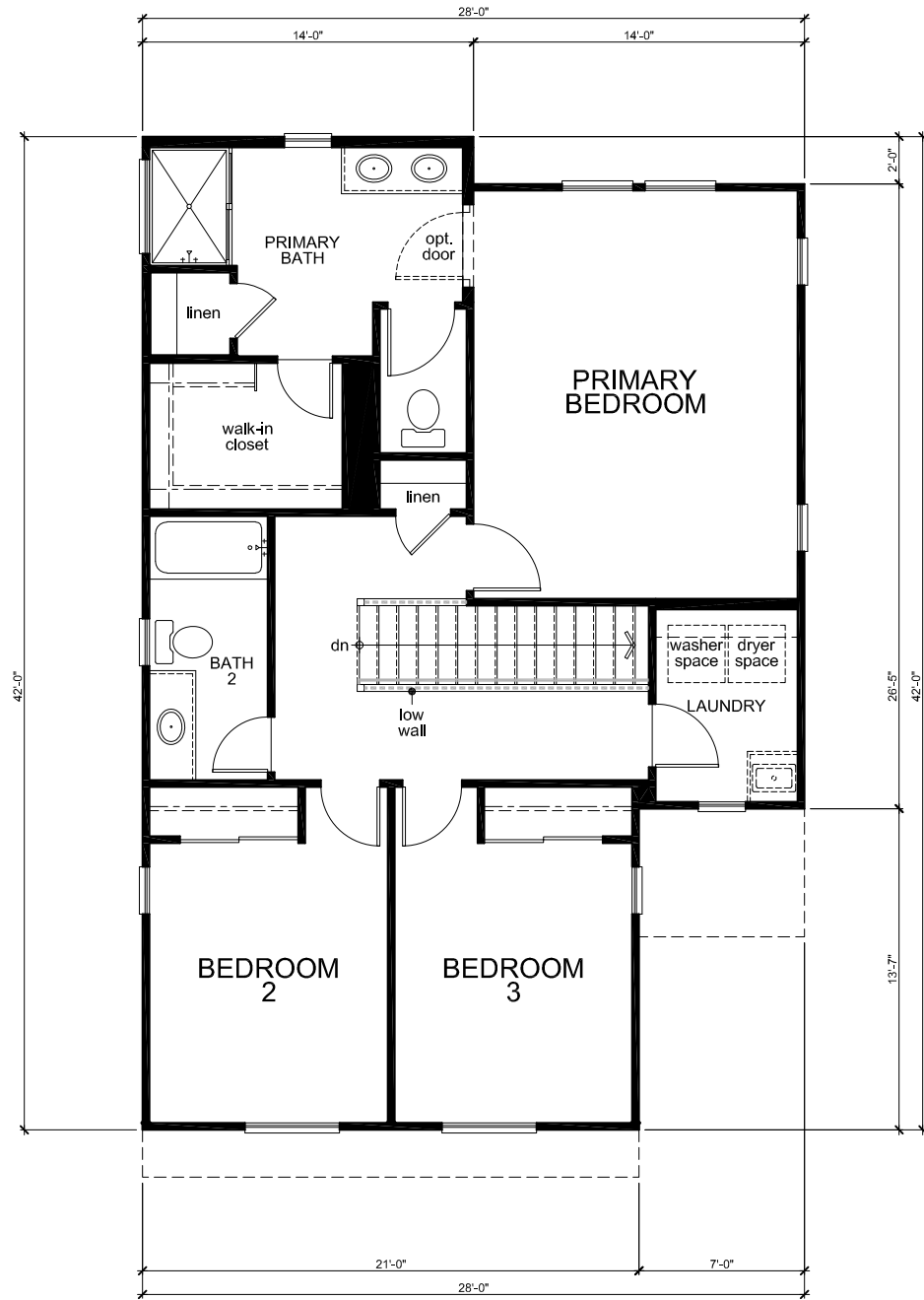

Second Floor Plan 'B'

SQUARE FOOTAGE			
PLAN 228.1677			
FIRST FLOOR AREA	665	SQ. FT.	
SECOND FLOOR AREA	1012	SQ. FT.	
TOTAL AREA	1677	SQ. FT.	
GARAGE AREA	440	SQ. FT.	
PORCH AREA(S)			
	ELEVATION 'A'	38	SQ. FT.
	ELEVATION 'B'	38	SQ. FT.
	ELEVATION 'C'	38	SQ. FT.

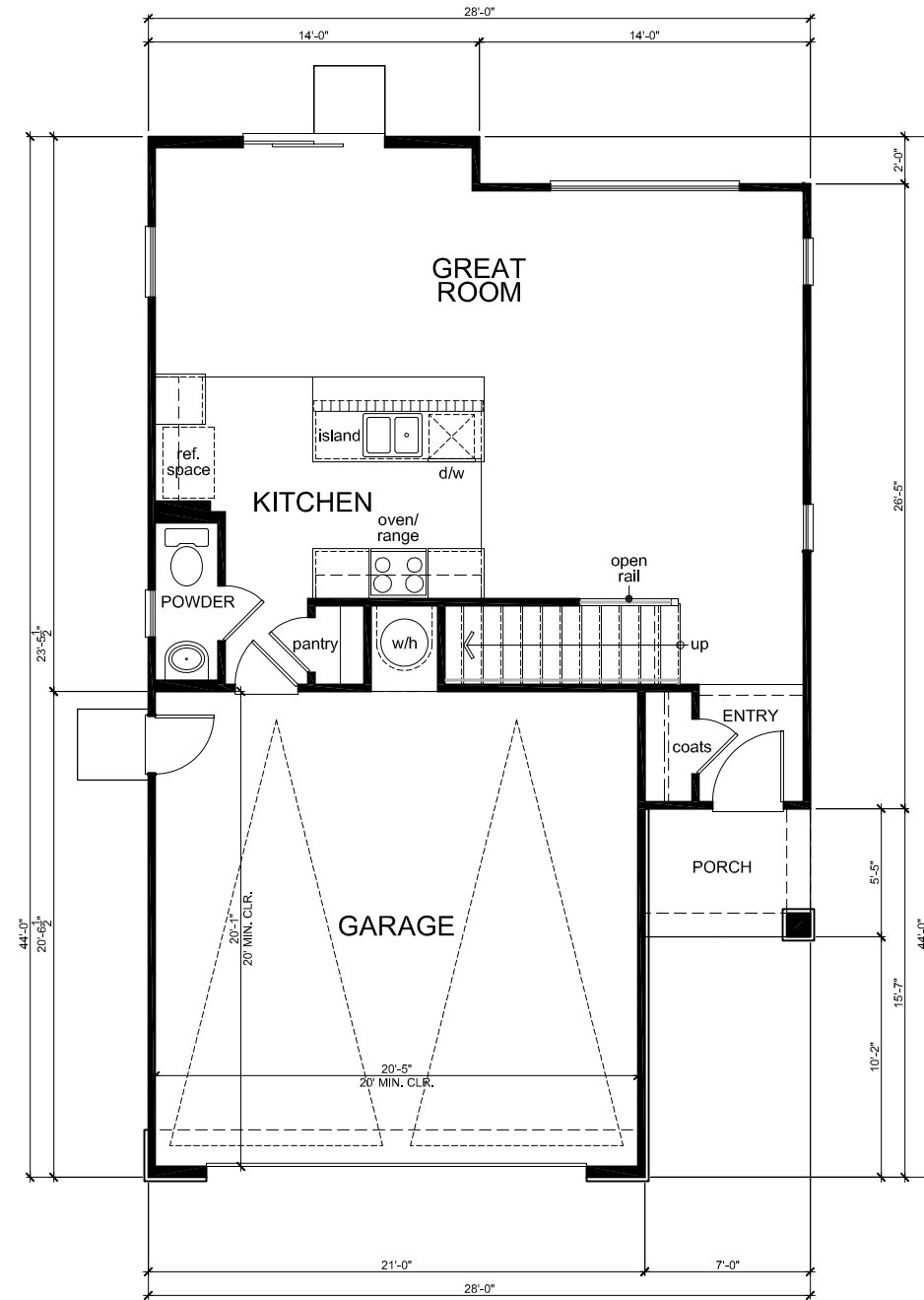

First Floor Plan 'B'

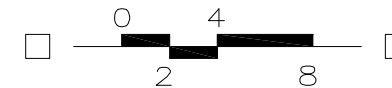

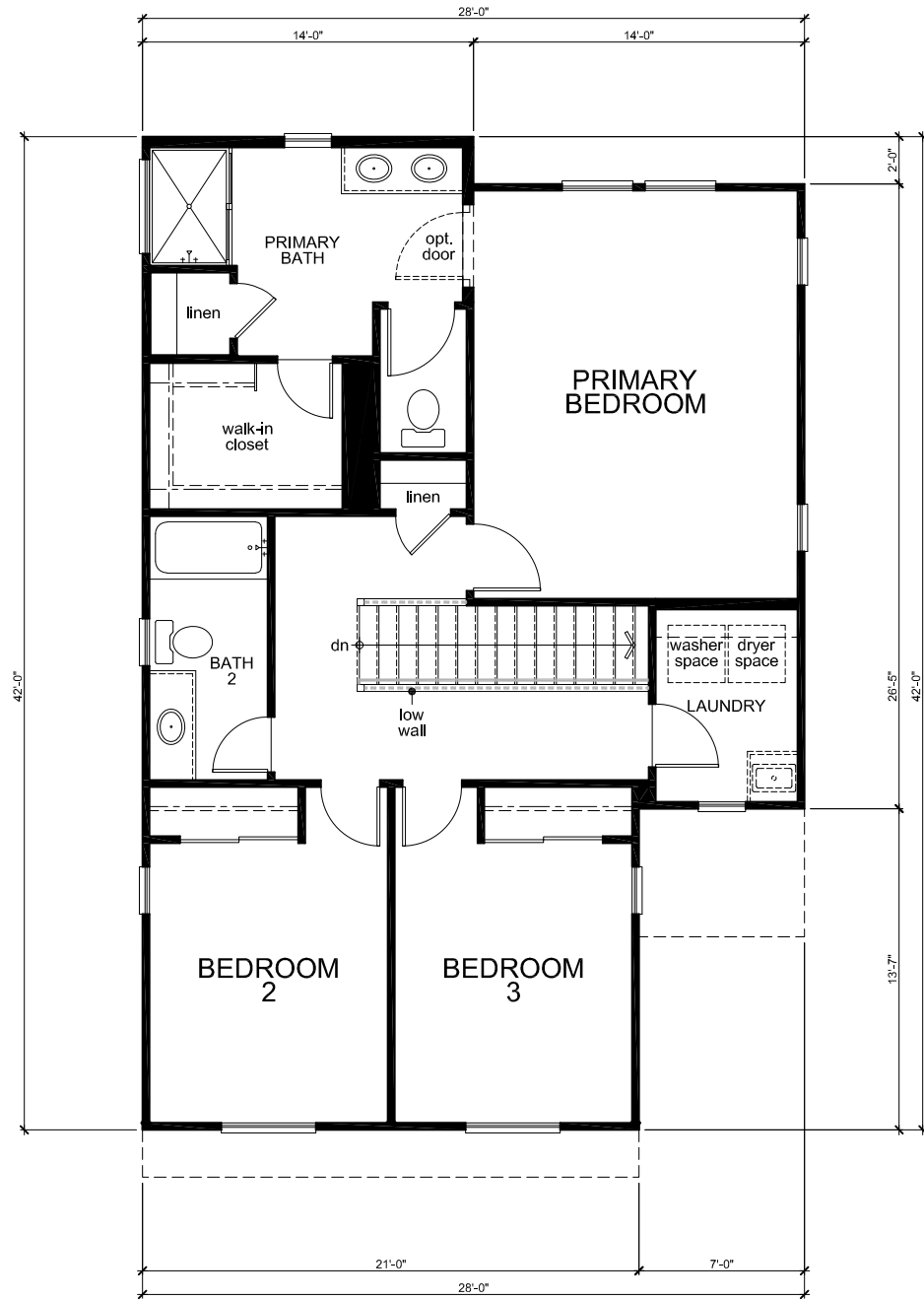

Second Floor Plan 'C'

SQUARE FOOTAGE			
PLAN 228.1677			
FIRST FLOOR AREA	665	SQ. FT.	
SECOND FLOOR AREA	1012	SQ. FT.	
TOTAL AREA	1677	SQ. FT.	
GARAGE AREA	440	SQ. FT.	
PORCH AREA(S)			
	ELEVATION 'A'	38	SQ. FT.
	ELEVATION 'B'	38	SQ. FT.
	ELEVATION 'C'	38	SQ. FT.

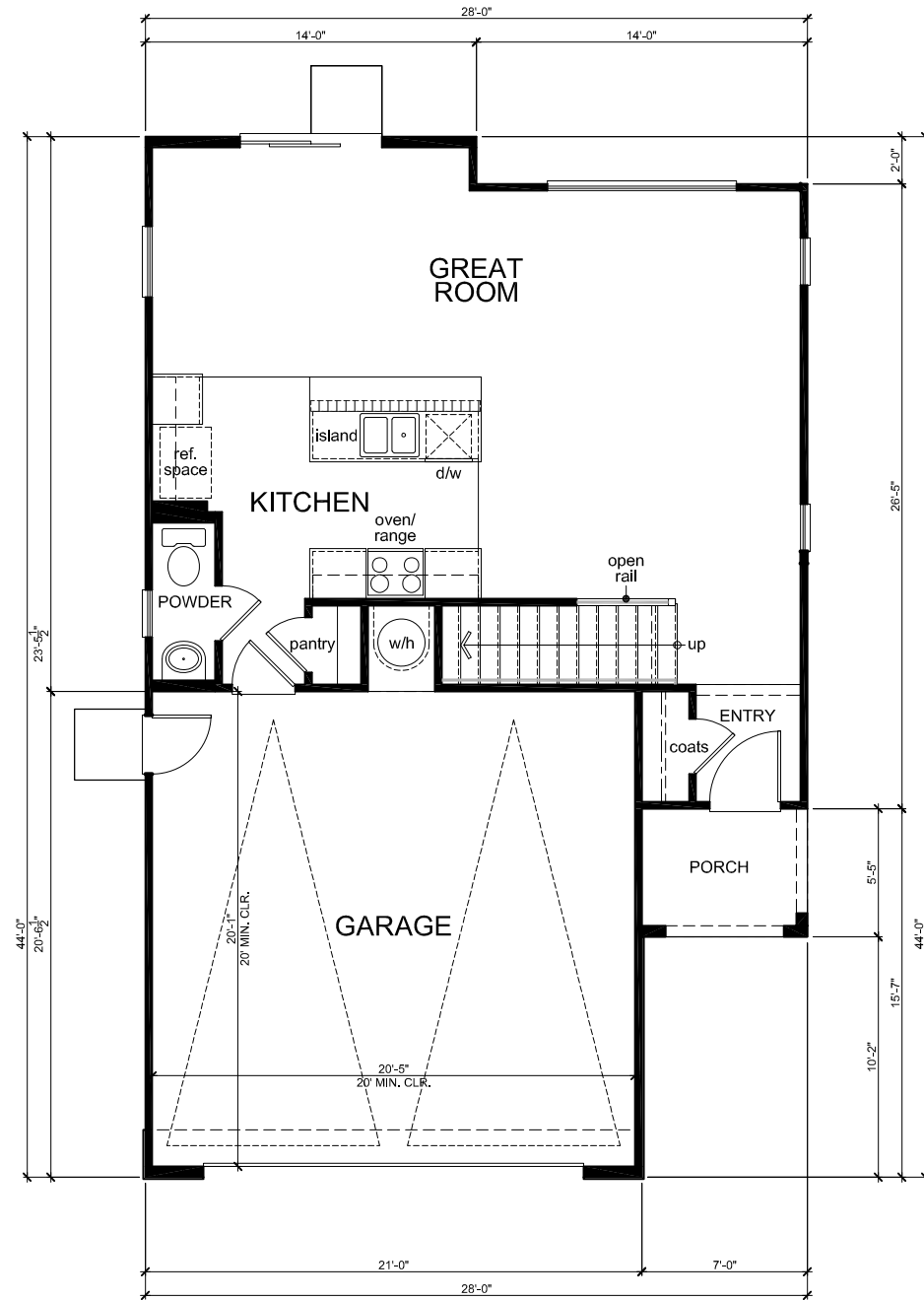

First Floor Plan 'C'

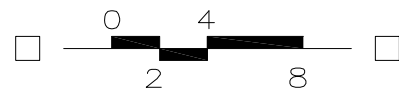



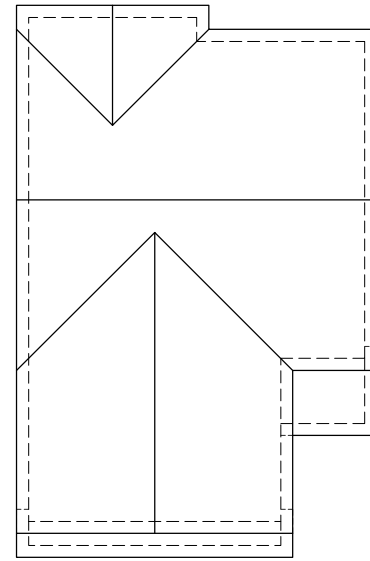

**'A' Spanish**  
4:12

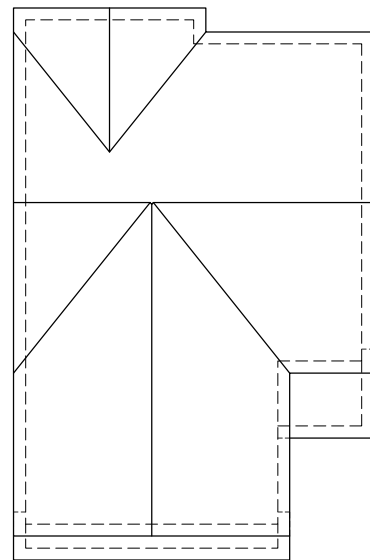

**'B' Craftsman**  
4:12 / 5:12

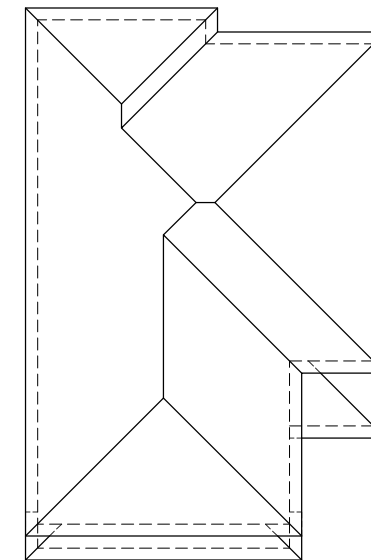

**'C' Italianate**  
4:12

Roof Plans

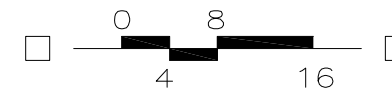

PLAN 1



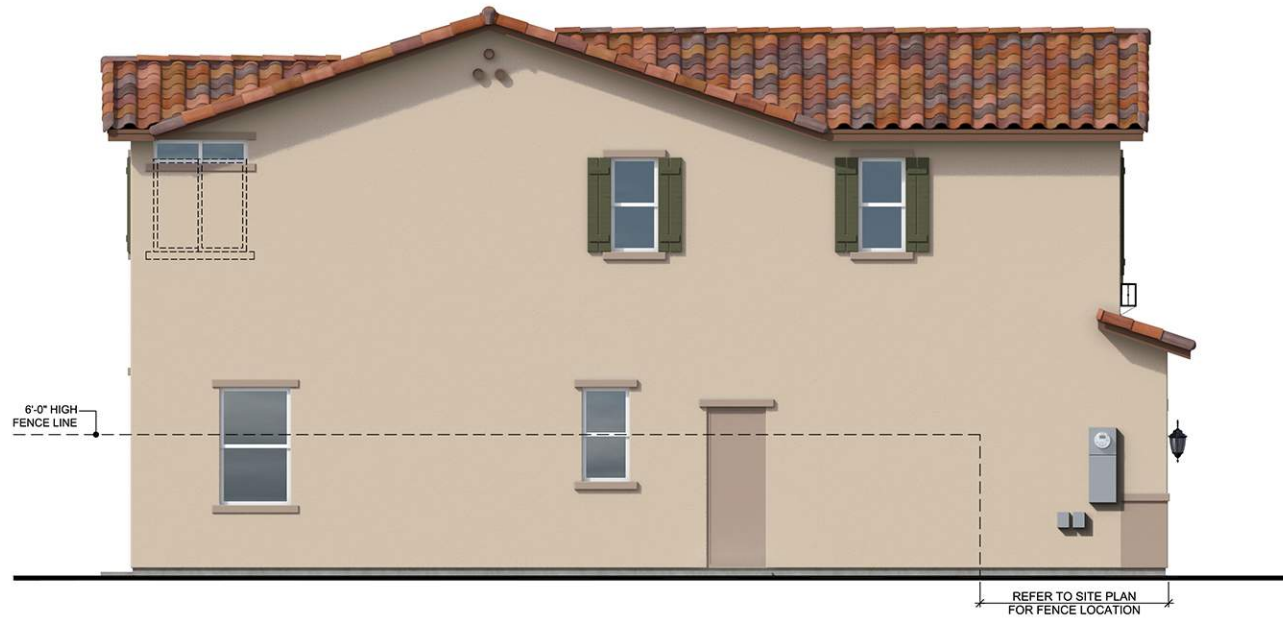

Left Elevation 'A' (Spanish)



Front Elevation 'A' (Spanish)



Right Elevation 'A' (Spanish)



Rear Elevation 'A' (Spanish)

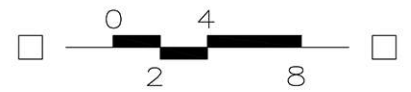

PLAN 1

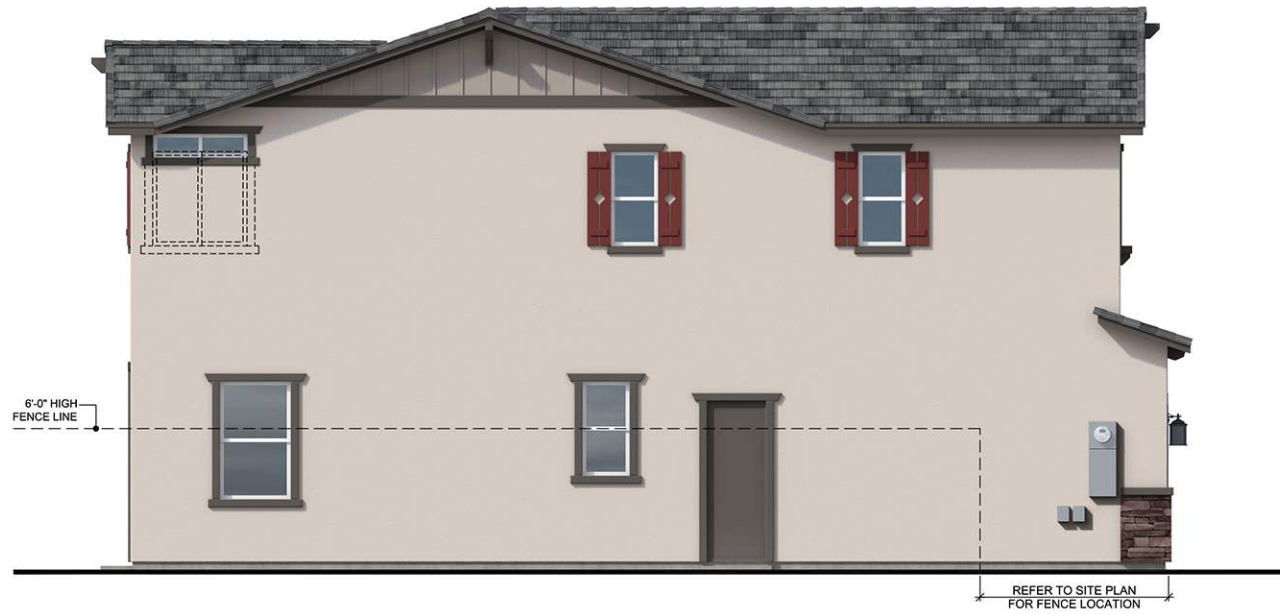

Left Elevation 'B' (Craftsman)



Front Elevation 'B' (Craftsman)

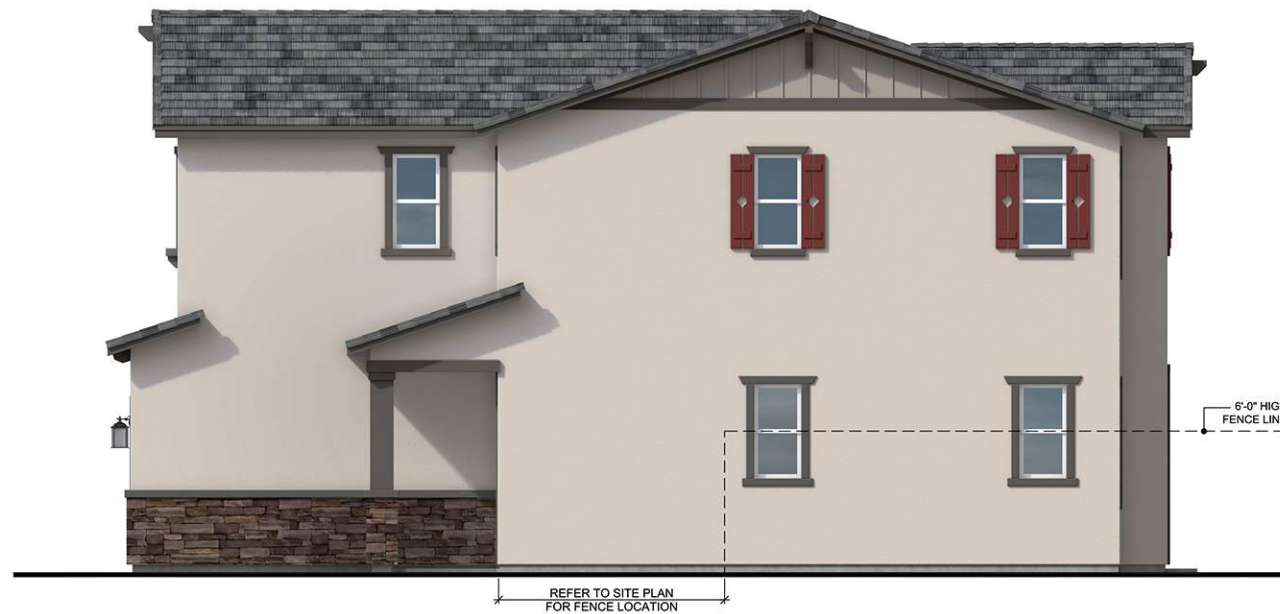

Right Elevation 'B' (Craftsman)



Rear Elevation 'B' (Craftsman)

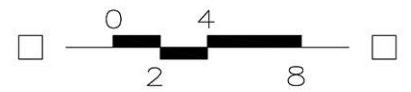

PLAN 1



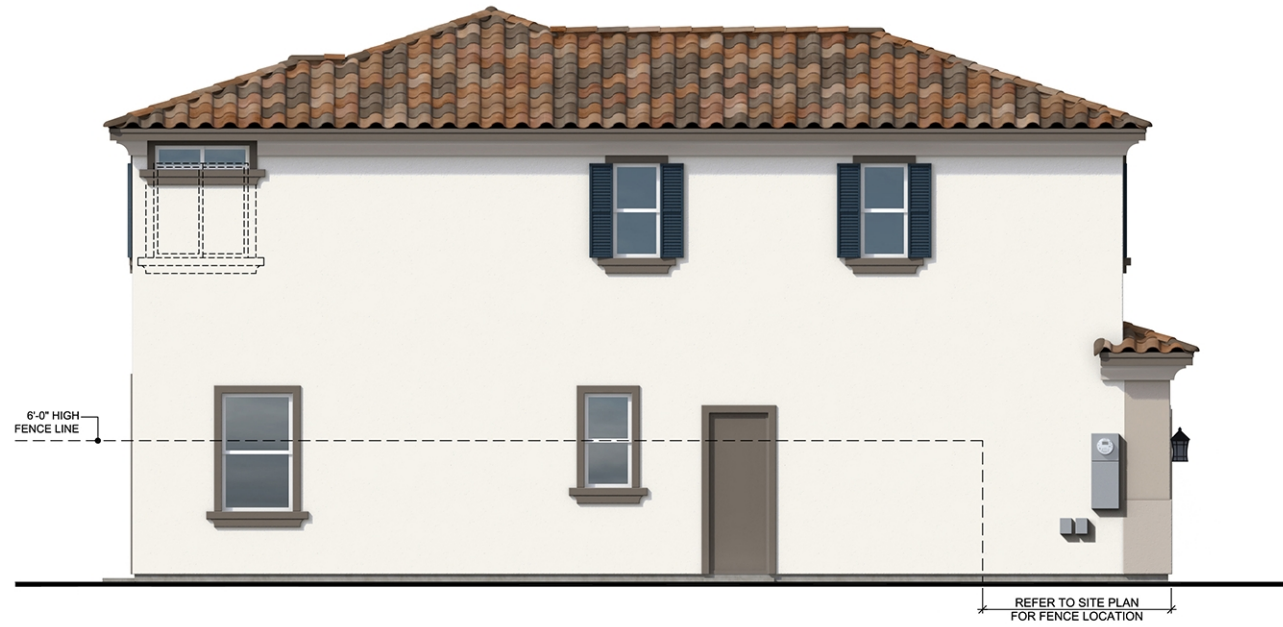

Left Elevation 'C' (Italianate)



Front Elevation 'C' (Italianate)



Right Elevation 'C' (Italianate)



Rear Elevation 'C' (Italianate)

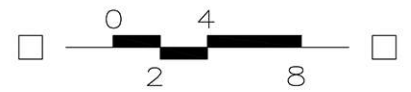

PLAN 1

**ELEVATION LEGEND**

- 1 CONCRETE 'S' TILE ROOFING
- 2 CONCRETE FLAT TILE ROOFING
- 3 WOOD FASCIA BOARD
- 4 STUCCO FINISH (16/20 SAND)
- 5 STUCCO OVER FOAM TRIM
- 6 DECORATIVE STUCCO FINISH OVER FOAM CORBELS/SHAPED FOAM TRIM
- 7 STUCCO COLUMN
- 8 VINYL WINDOW SYSTEM
- 9 COMPOSITE ENTRY DOOR
- 10 METAL SECTIONAL GARAGE DOOR
- 11 DECORATIVE SHUTTERS
- 12 DECORATIVE GABLE END DETAIL
- 13 COACH LIGHTS
- 14 DECORATIVE OUTLOOKERS
- 15 GARAGE WINDOWS
- 16 ADDRESS PLAQUE
- 17 DECORATIVE CLAY PIPE
- 18 STUCCO OVER FOAM POTSHELF
- 19 BOARD AND BATTEN
- 20 WOOD COLUMN
- 21 WOOD POST
- 22 DECORATIVE TILE
- 23 BRICK VENEER
- 24 STONE VENEER
- 25 WROUGHT IRON POTSHELF
- 26 EXPOSED RAFTER TAILS



Elevation 'A' (Spanish)

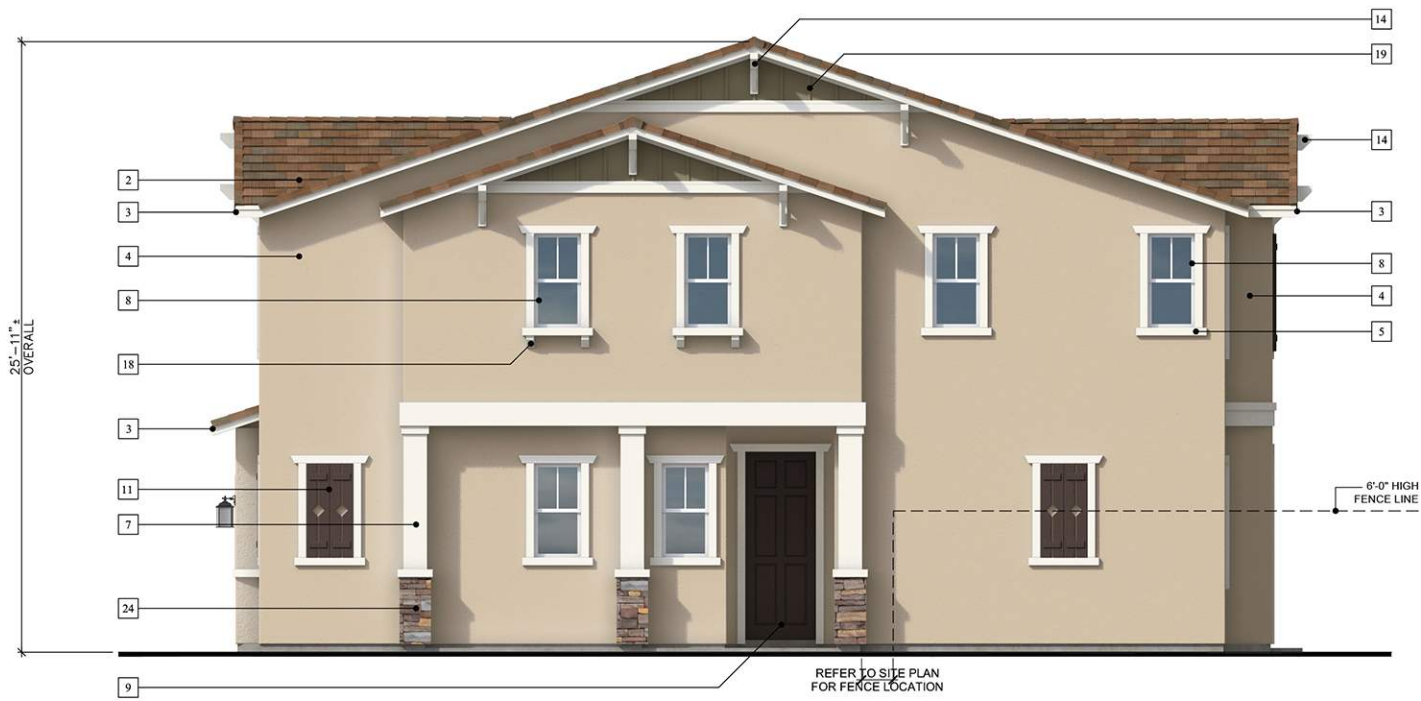

Elevation 'B' (Craftsman)



Elevation 'C' (Italianate)

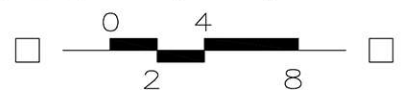



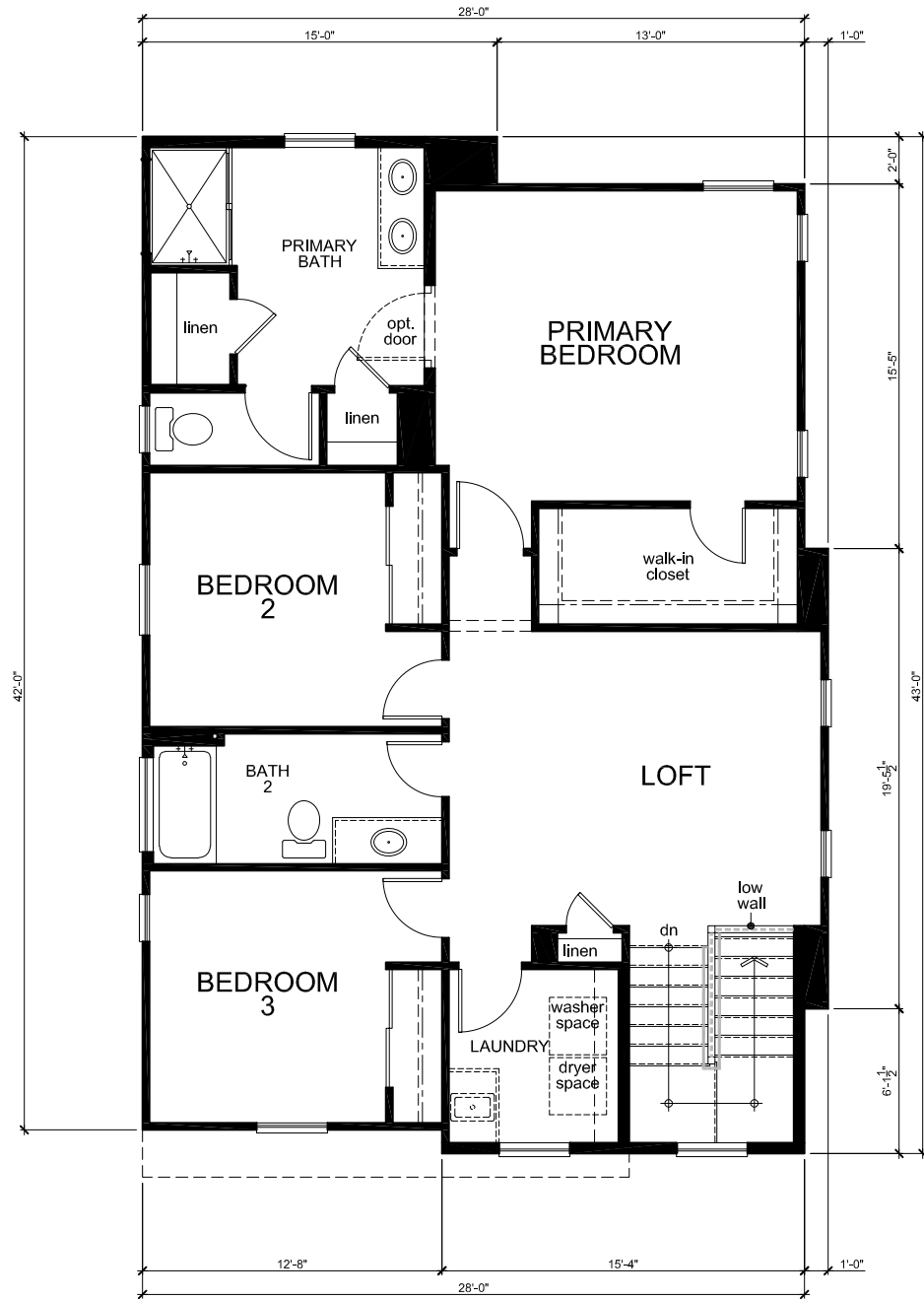

Second Floor Plan 'A'

SQUARE FOOTAGE			
PLAN 228.1877			
FIRST FLOOR AREA	772	SQ. FT.	
SECOND FLOOR AREA	1105	SQ. FT.	
<b>TOTAL AREA</b>	<b>1877</b>	<b>SQ. FT.</b>	
GARAGE AREA	417	SQ. FT.	
PORCH AREA(S)	14	SQ. FT.	
	ELEVATION 'A'	14	SQ. FT.
	ELEVATION 'B'	29	SQ. FT.
	ELEVATION 'C'	14	SQ. FT.

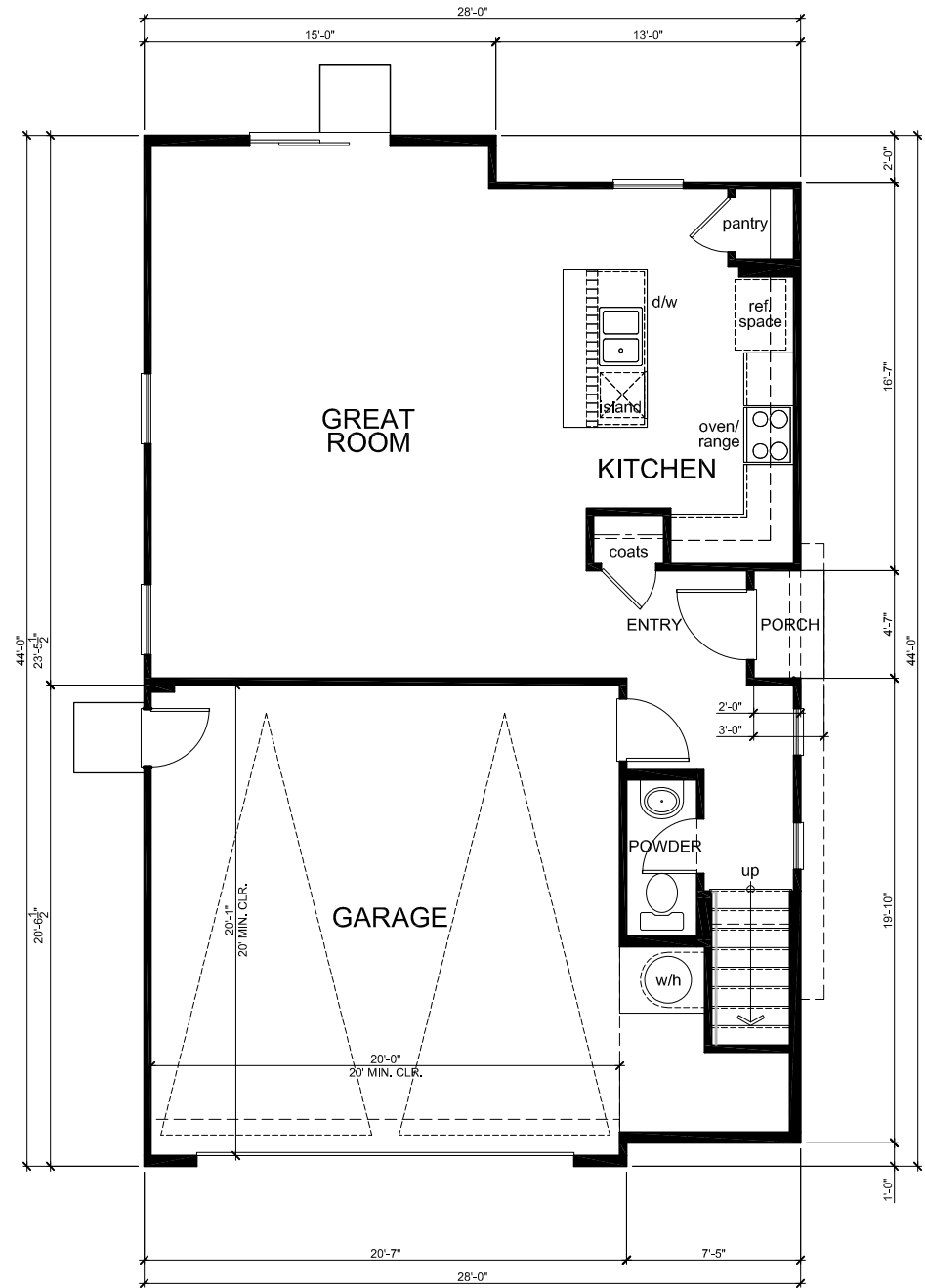

First Floor Plan 'A'

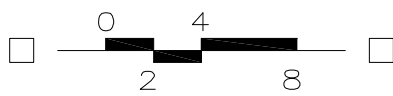

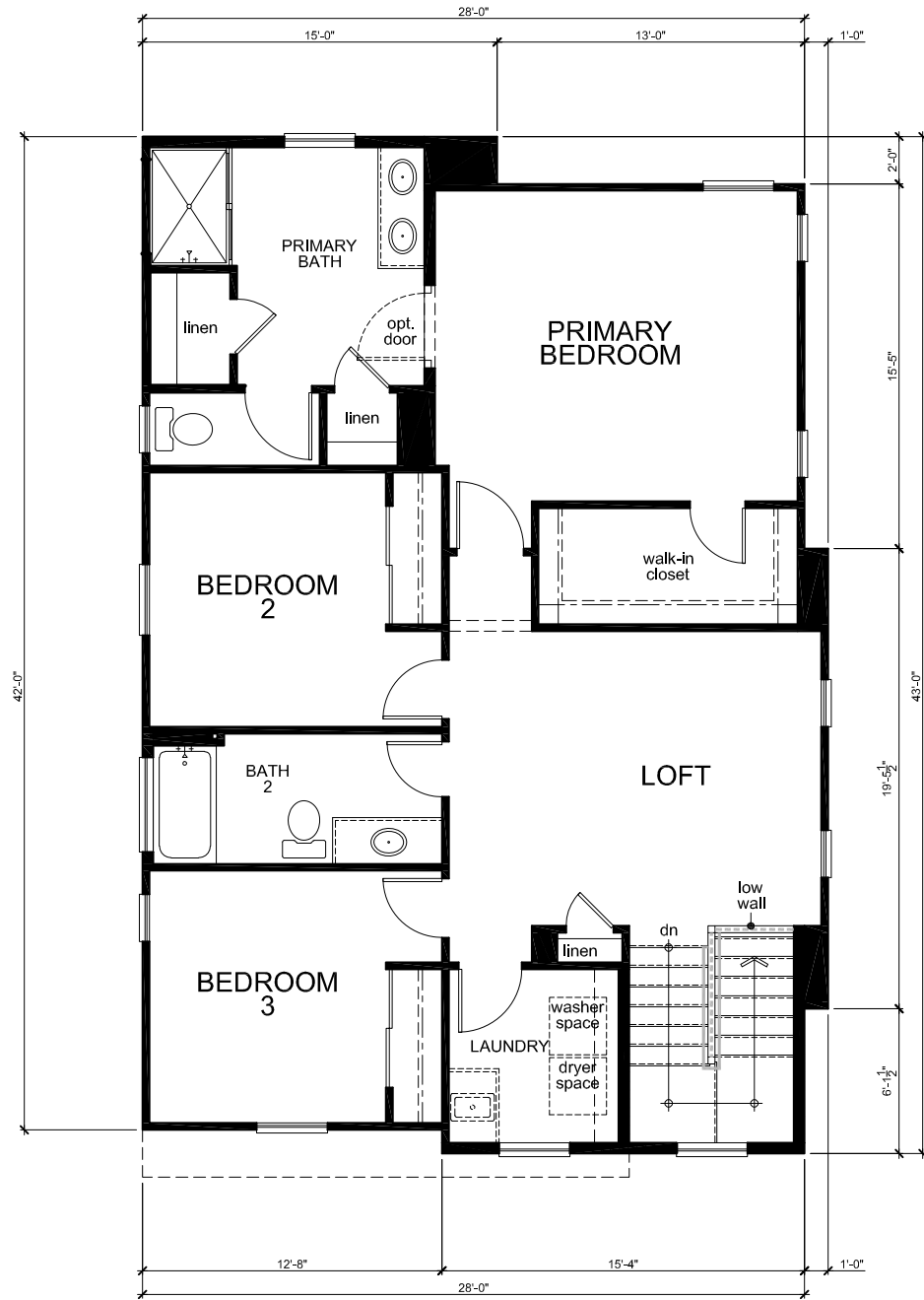

Second Floor Plan 'B'

SQUARE FOOTAGE			
PLAN 228.1877			
FIRST FLOOR AREA	712	SQ. FT.	
SECOND FLOOR AREA	1105	SQ. FT.	
TOTAL AREA	1817	SQ. FT.	
GARAGE AREA	417	SQ. FT.	
PORCH AREA(S)	14	SQ. FT.	
	ELEVATION 'A'	14	SQ. FT.
	ELEVATION 'B'	29	SQ. FT.
	ELEVATION 'C'	14	SQ. FT.

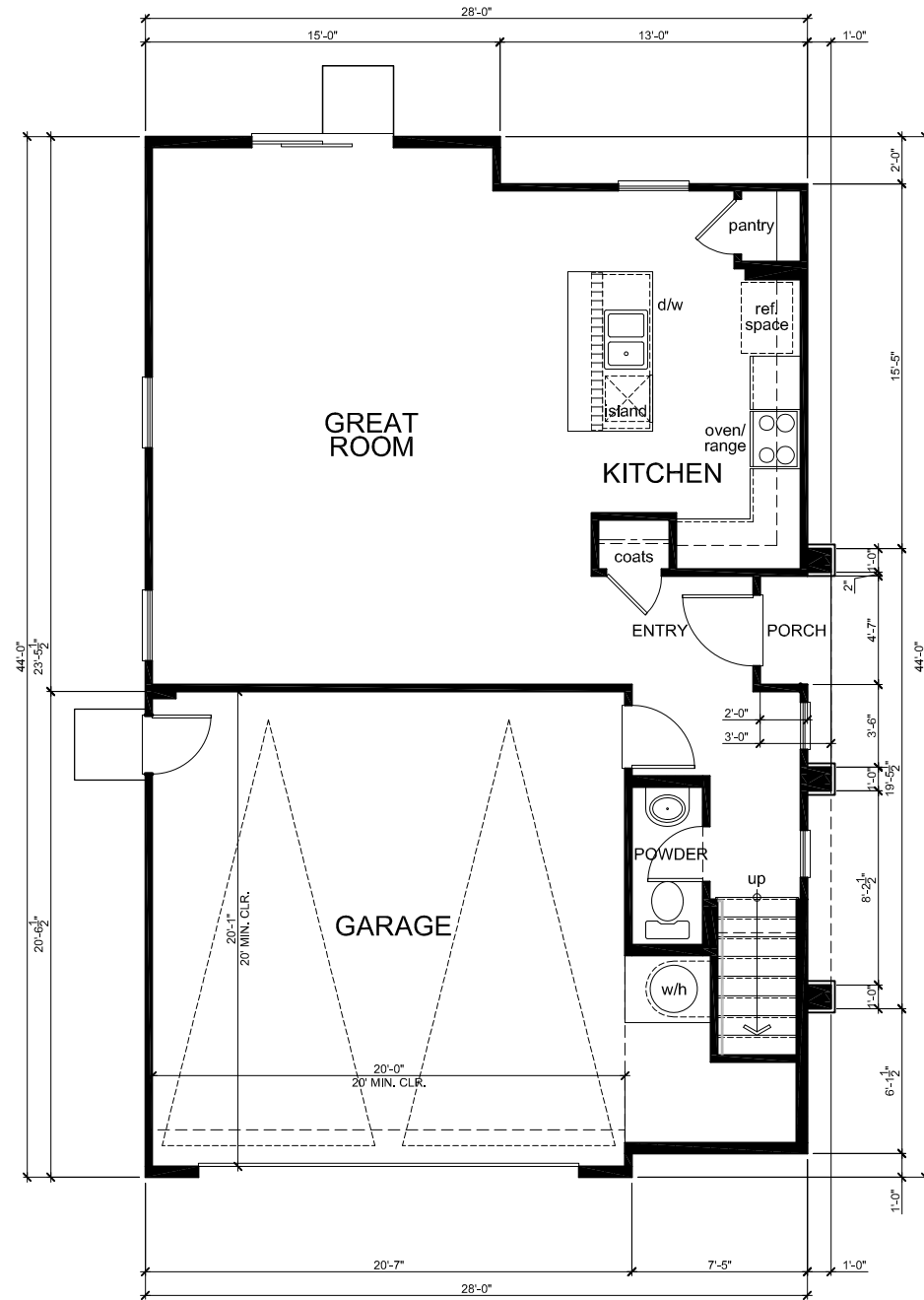

First Floor Plan 'B'

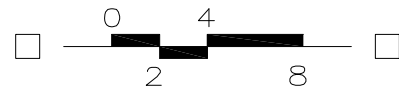

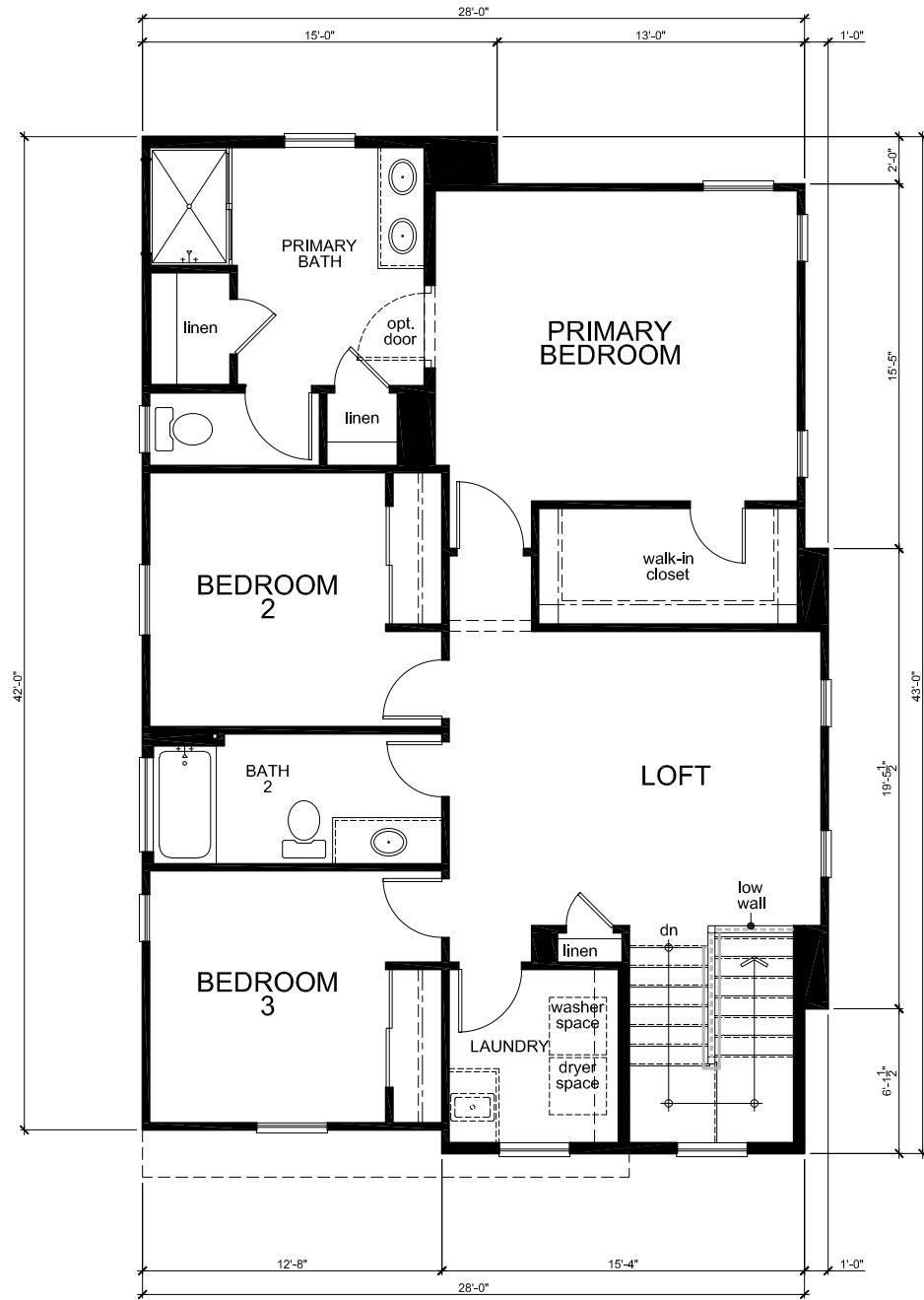

Second Floor Plan 'C'

SQUARE FOOTAGE			
PLAN 228.1877			
FIRST FLOOR AREA	772	SQ. FT.	
SECOND FLOOR AREA	1105	SQ. FT.	
TOTAL AREA	1877	SQ. FT.	
GARAGE AREA	417	SQ. FT.	
PORCH AREA(S)	14	SQ. FT.	
	ELEVATION 'A'	14	SQ. FT.
	ELEVATION 'B'	29	SQ. FT.
	ELEVATION 'C'	14	SQ. FT.

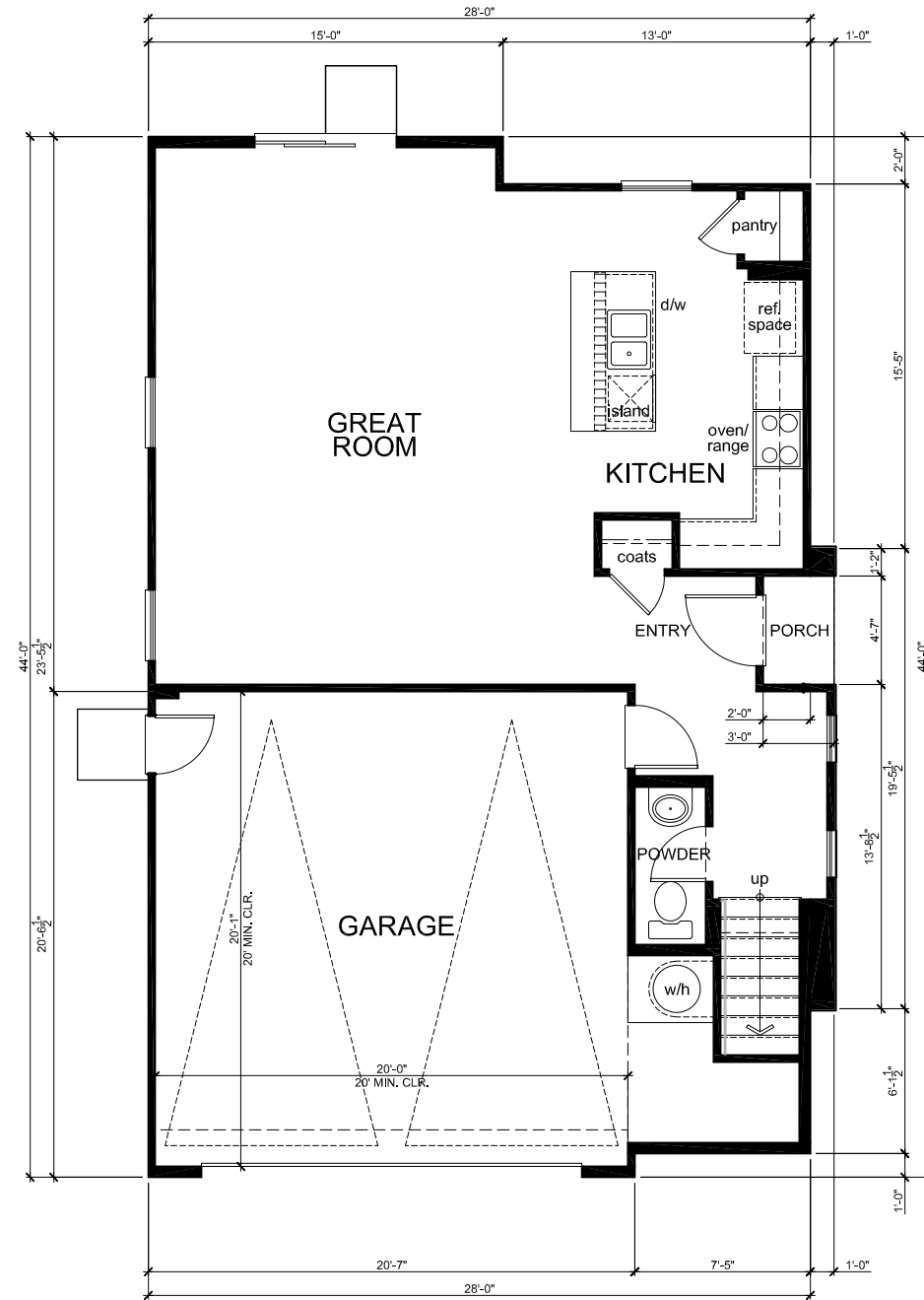

First Floor Plan 'C'

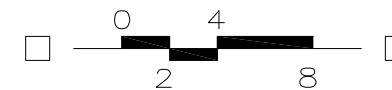

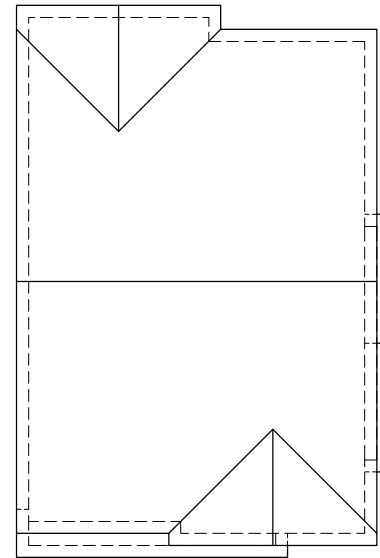

**'A' Spanish**  
4:12

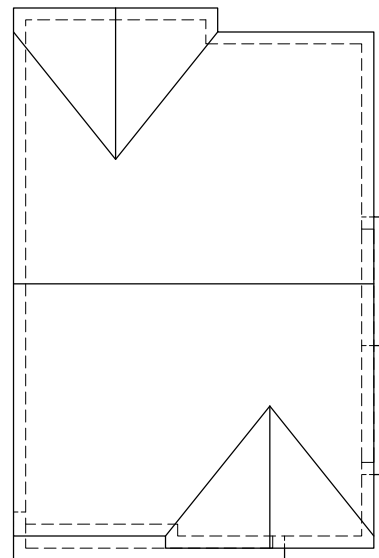

**'B' Craftsman**  
4:12 / 5:12

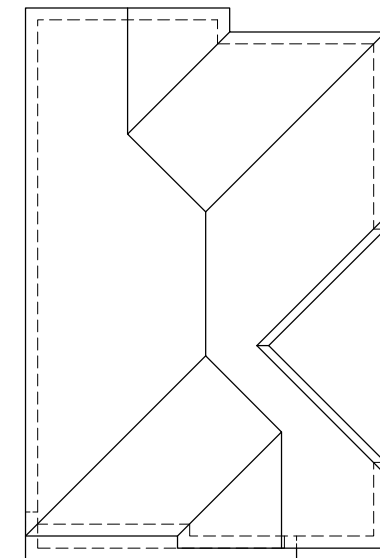

**'C' Italianate**  
4:12

Roof Plans

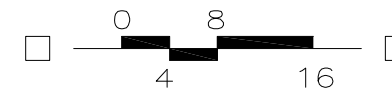

PLAN 2





Rear Elevation 'A' (Spanish)



Left Elevation 'A' (Spanish)



Front Elevation 'A' (Spanish)



Right Elevation 'A' (Spanish)

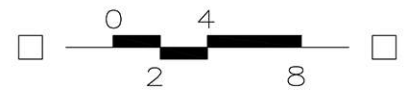

PLAN 2



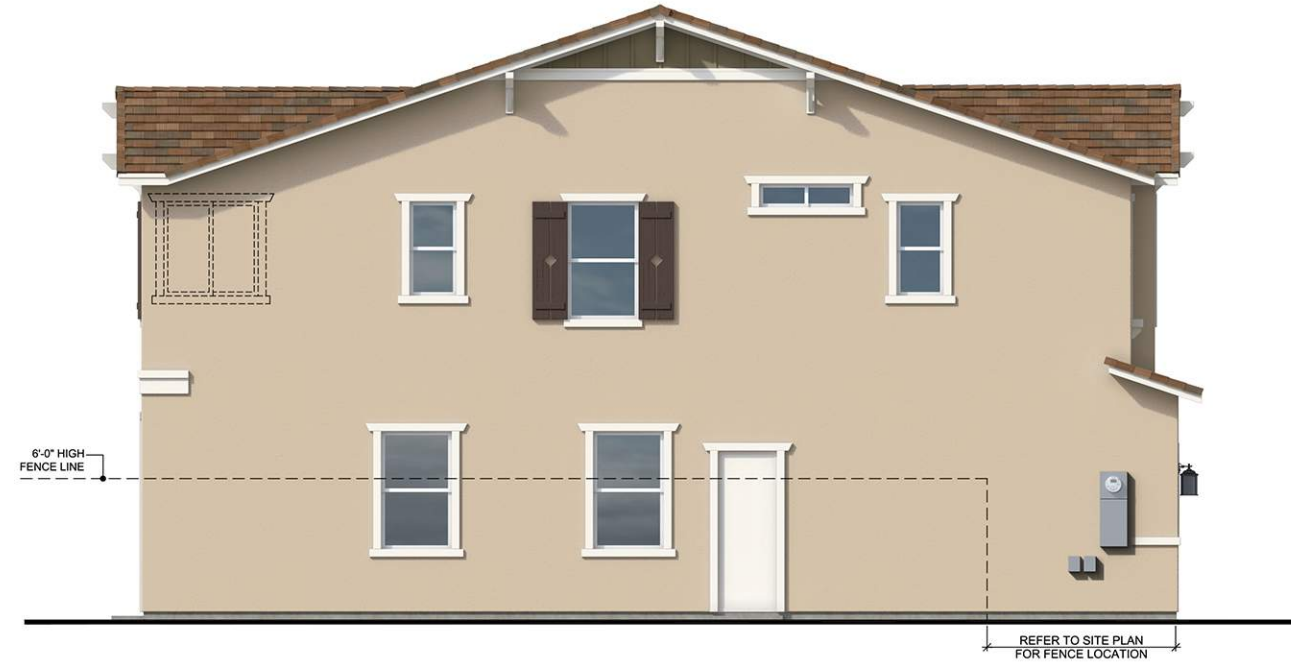

Rear Elevation 'B' (Craftsman)



Left Elevation 'B' (Craftsman)



Front Elevation 'B' (Craftsman)



Right Elevation 'B' (Craftsman)

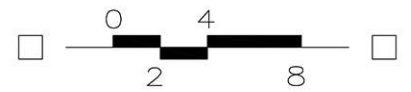

PLAN 2



Rear Elevation 'C' (Italianate)



Left Elevation 'C' (Italianate)



Front Elevation 'C' (Italianate)



Right Elevation 'C' (Italianate)

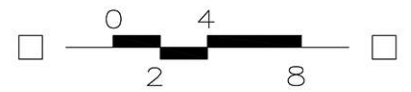

PLAN 2



**ELEVATION LEGEND**

- 1 CONCRETE 'S' TILE ROOFING
- 2 CONCRETE FLAT TILE ROOFING
- 3 WOOD FASCIA BOARD
- 4 STUCCO FINISH (16/20 SAND)
- 5 STUCCO OVER FOAM TRIM
- 6 DECORATIVE STUCCO FINISH OVER FOAM CORBELS/SHAPED FOAM TRIM
- 7 STUCCO COLUMN
- 8 VINYL WINDOW SYSTEM
- 9 COMPOSITE ENTRY DOOR
- 10 METAL SECTIONAL GARAGE DOOR
- 11 DECORATIVE SHUTTERS
- 12 DECORATIVE GABLE END DETAIL
- 13 COACH LIGHTS
- 14 DECORATIVE OUTLOOKERS
- 15 GARAGE WINDOWS
- 16 ADDRESS PLAQUE
- 17 DECORATIVE CLAY PIPE
- 18 STUCCO OVER FOAM POTSHelf
- 19 BOARD AND BATTEN
- 20 WOOD COLUMN
- 21 WOOD POST
- 22 DECORATIVE TILE
- 23 BRICK VENEER
- 24 STONE VENEER
- 25 WROUGHT IRON POTSHelf
- 26 EXPOSED RAFTER TAILS



Elevation 'A' (Spanish)



Elevation 'B' (Craftsman)



Elevation 'C' (Italianate)

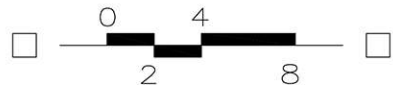

PLAN 3

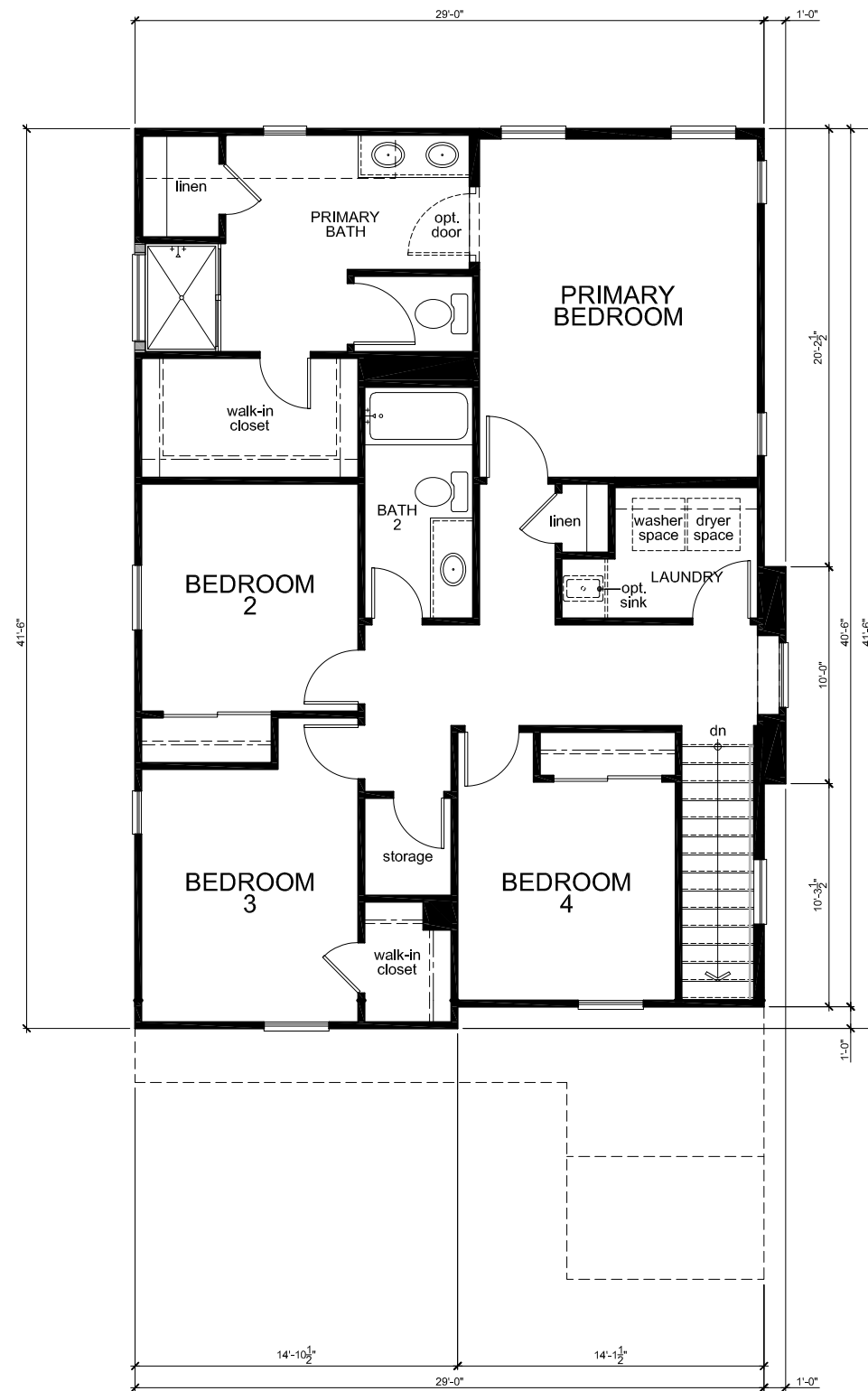

Second Floor Plan 'A'

SQUARE FOOTAGE			
PLAN 229.2000			
FIRST FLOOR AREA	855	SQ. FT.	
SECOND FLOOR AREA	1145	SQ. FT.	
<b>TOTAL AREA</b>	<b>2000</b>	<b>SQ. FT.</b>	
GARAGE AREA	425	SQ. FT.	
PORCH AREA(S)	51	SQ. FT.	
	ELEVATION 'A'	51	SQ. FT.
	ELEVATION 'B'	51	SQ. FT.
	ELEVATION 'C'	51	SQ. FT.

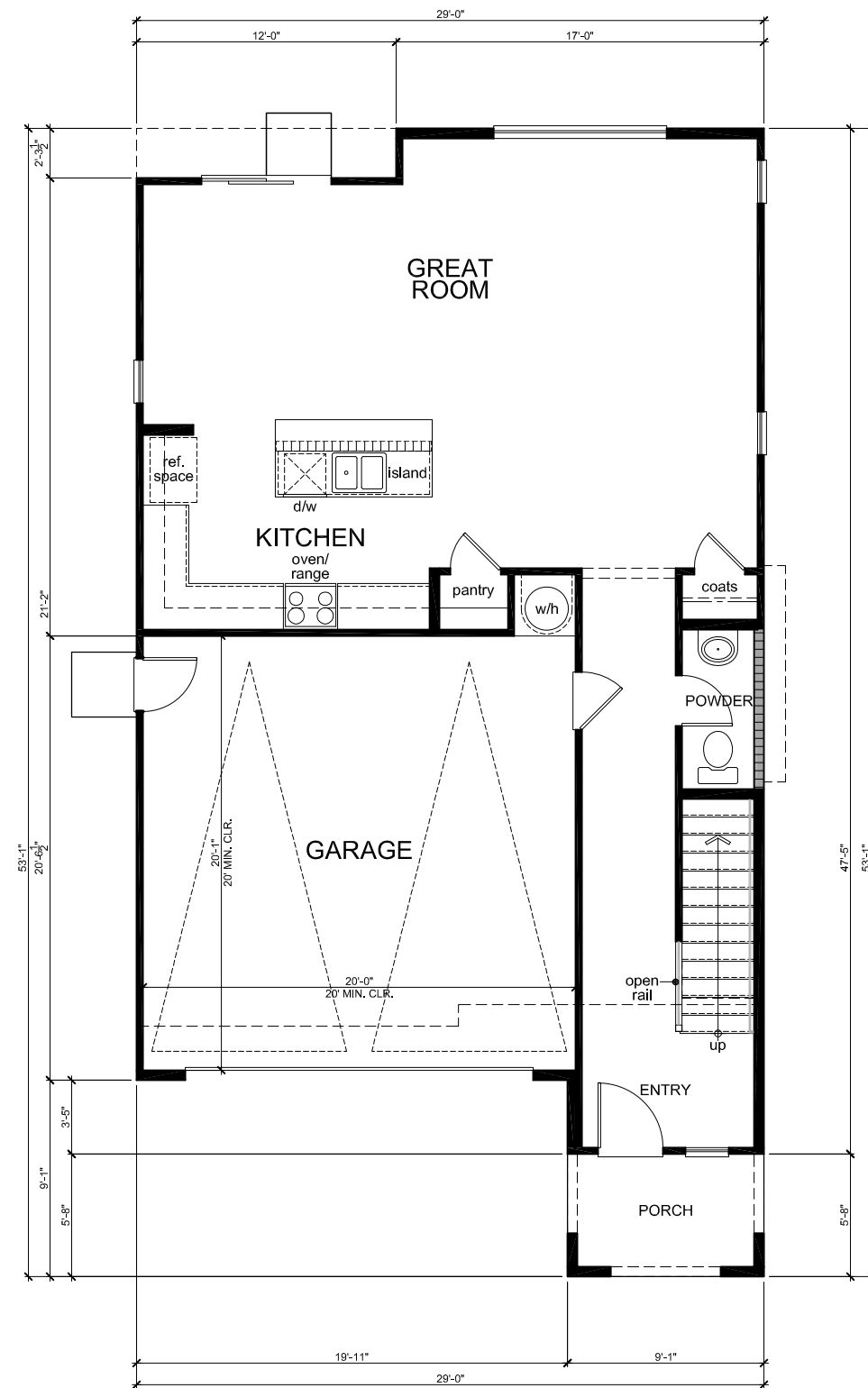

First Floor Plan 'A'

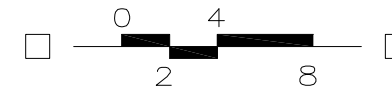

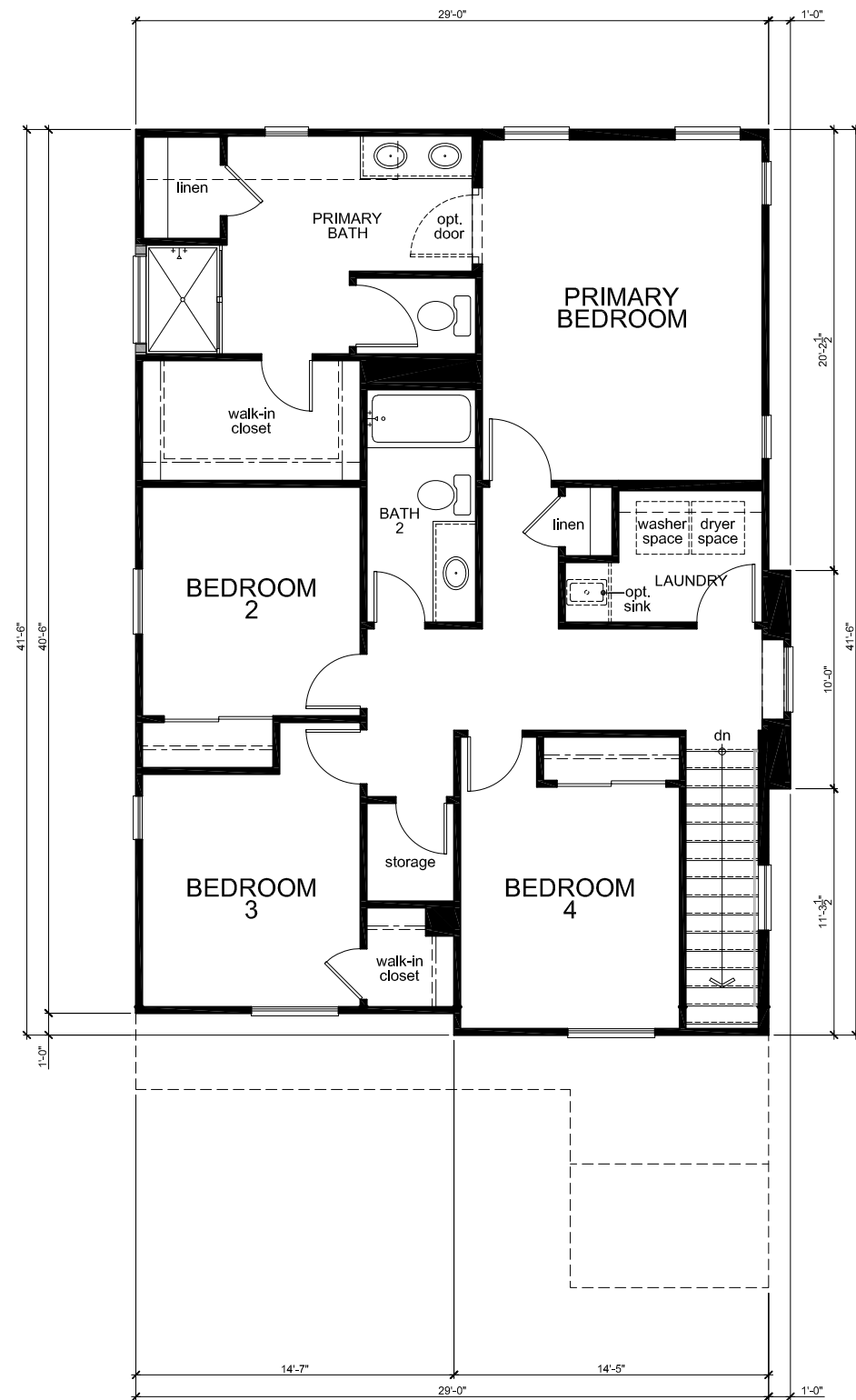

Second Floor Plan 'B'

SQUARE FOOTAGE			
PLAN 229.2000			
FIRST FLOOR AREA	855	SQ. FT.	
SECOND FLOOR AREA	1145	SQ. FT.	
<b>TOTAL AREA</b>	<b>2000</b>	<b>SQ. FT.</b>	
GARAGE AREA	425	SQ. FT.	
PORCH AREA(S)	51	SQ. FT.	
	ELEVATION 'A'	51	SQ. FT.
	ELEVATION 'B'	51	SQ. FT.
	ELEVATION 'C'	51	SQ. FT.

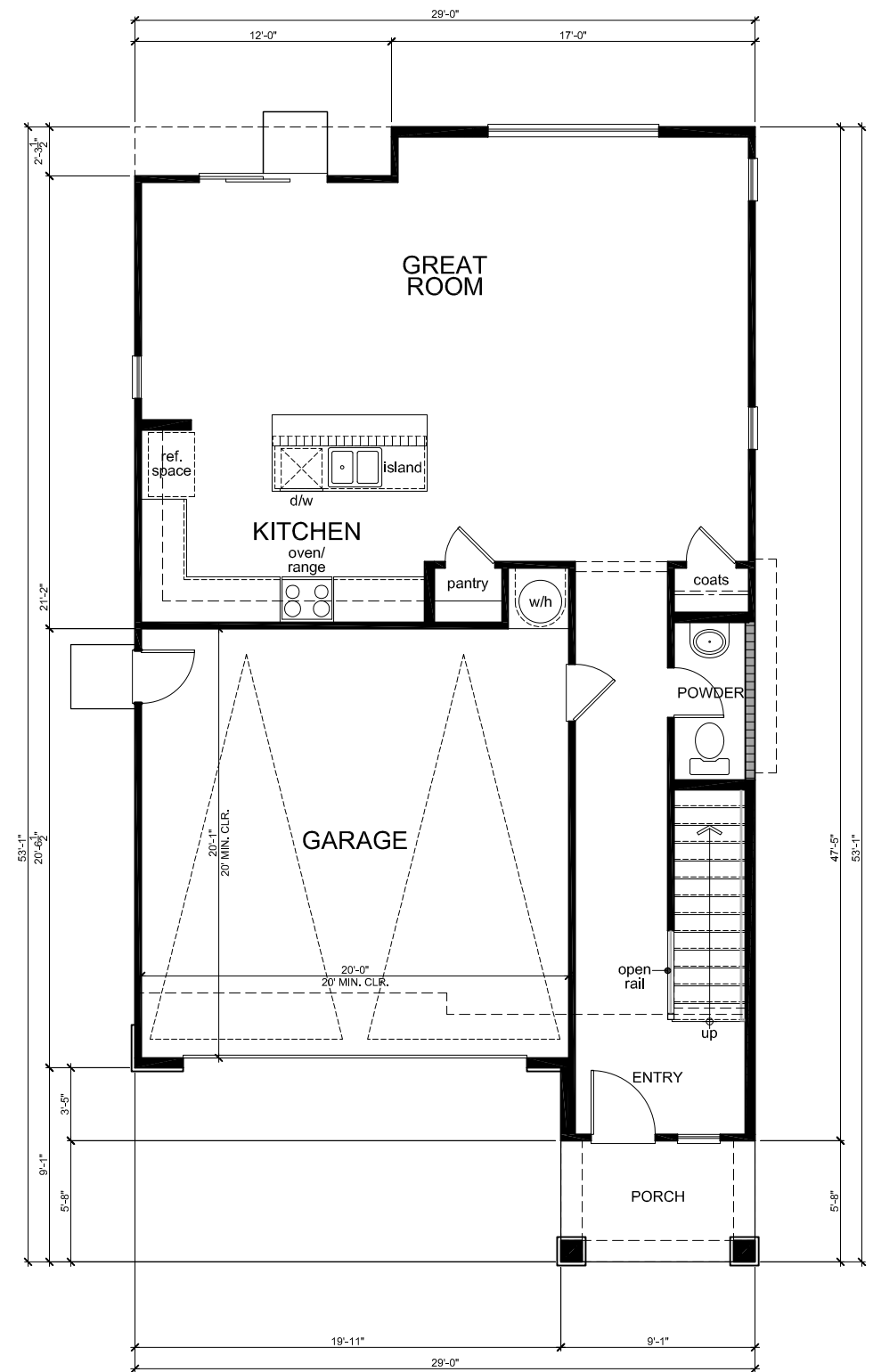

First Floor Plan 'B'

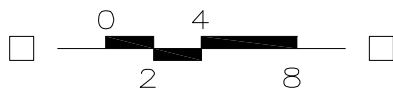



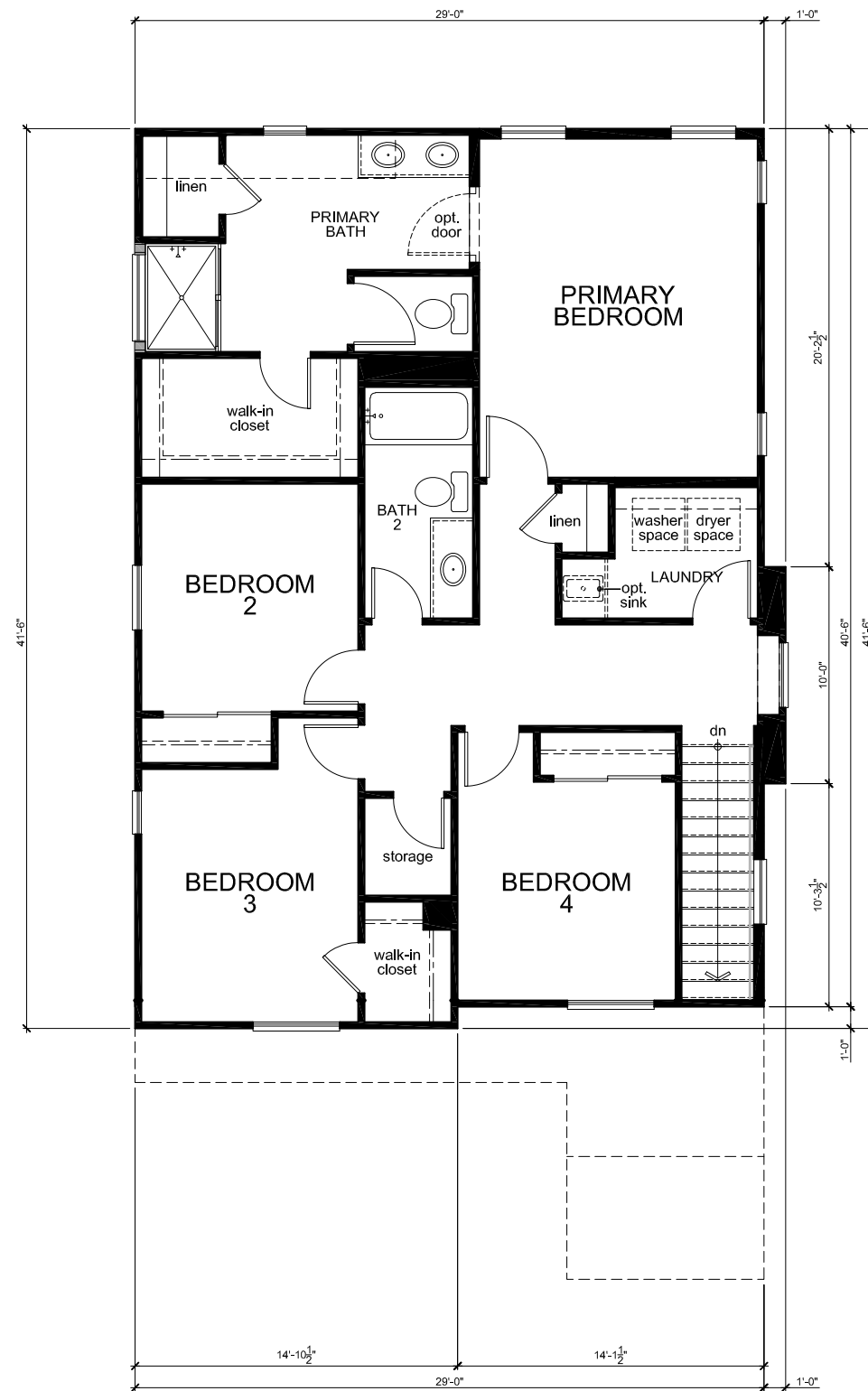

Second Floor Plan 'C'

SQUARE FOOTAGE			
PLAN 229.2000			
FIRST FLOOR AREA	855	SQ. FT.	
SECOND FLOOR AREA	1145	SQ. FT.	
<b>TOTAL AREA</b>	<b>2000</b>	<b>SQ. FT.</b>	
GARAGE AREA	425	SQ. FT.	
PORCH AREA(S)	51	SQ. FT.	
	ELEVATION 'A'	51	SQ. FT.
	ELEVATION 'B'	51	SQ. FT.
	ELEVATION 'C'	51	SQ. FT.

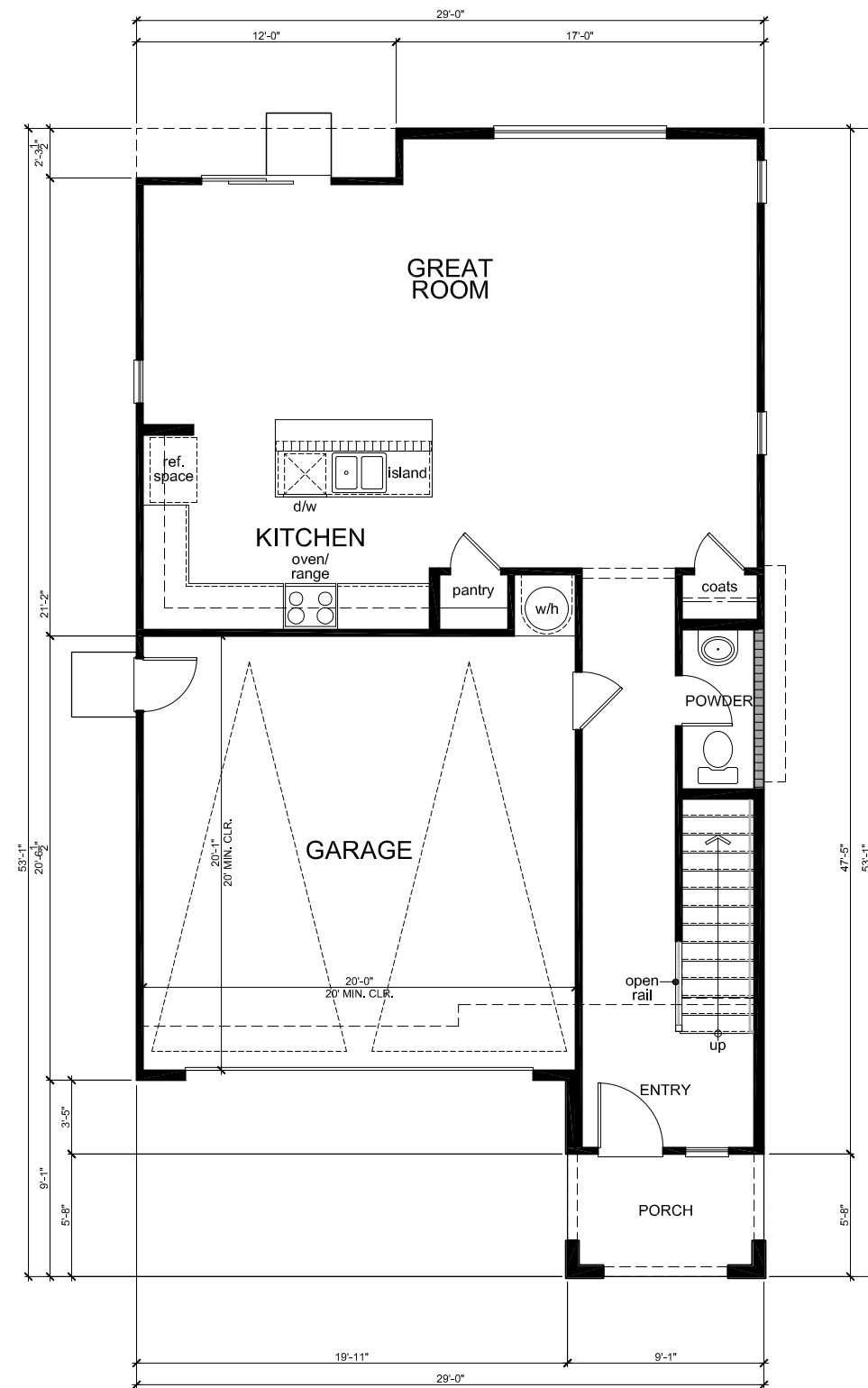

First Floor Plan 'C'

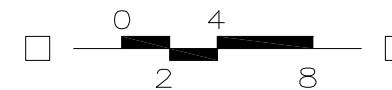

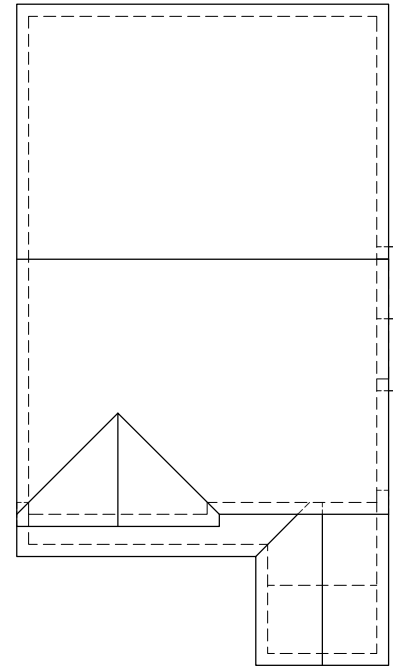

'A' Spanish  
4:12

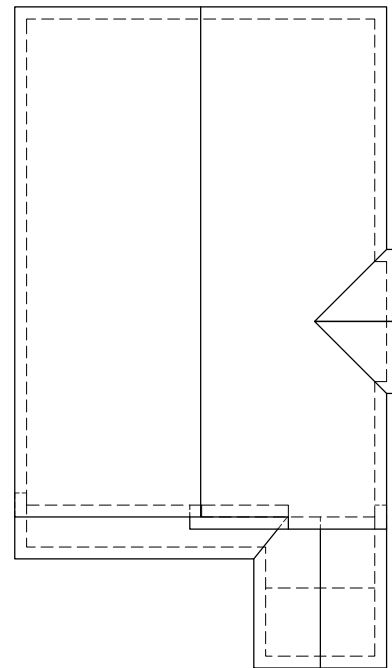

'B' Craftsman  
5:12

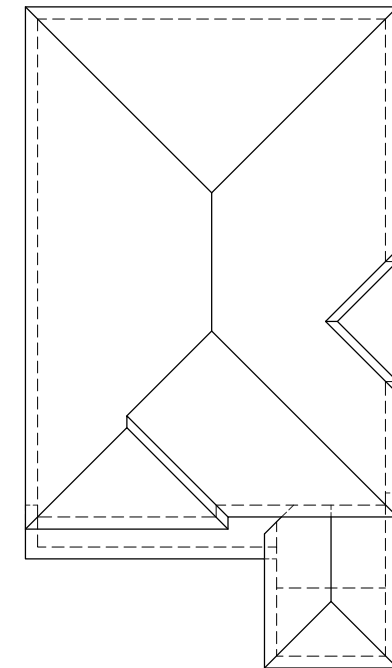

'C' Italianate  
4:12

Roof Plans

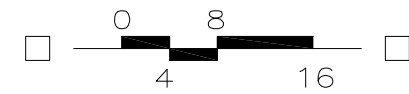

PLAN 3





Left Elevation 'A' (Spanish)



Front Elevation 'A' (Spanish)



Right Elevation 'A' (Spanish)



Rear Elevation 'A' (Spanish)

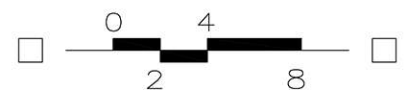



Left Elevation 'B' (Craftsman)



Front Elevation 'B' (Craftsman)



Right Elevation 'B' (Craftsman)



Rear Elevation 'B' (Craftsman)

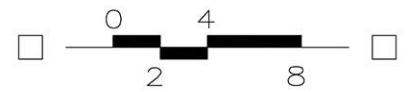

PLAN 3





Left Elevation 'C' (Italianate)



Front Elevation 'C' (Italianate)



Right Elevation 'C' (Italianate)



Rear Elevation 'C' (Italianate)

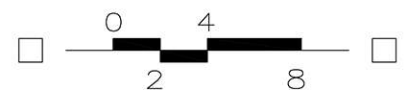

PLAN 3